

 Custom  
**callero**  
Storage with style.

 **recycle**

[www.gratnells.com](http://www.gratnells.com)

*Gratnells*

 Custom  
**callero**  
Storage with style.



# Assembly instructions

Instrucciones de montaje  
Instructions de montage

[www.gratnells.com](http://www.gratnells.com)



*Gratnells*

# Custom callero

Storage with style.



# Contents / Contenu / Contenido

P4 - P10 : Starter units / unités initiales / unidades iniciales

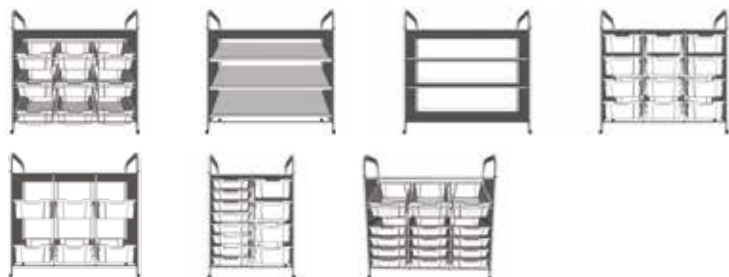

P11 - P22 : Additional units / unités supplémentaires / unidades adicionales



P22 - P31 : Tall starter units / unités hautes initiales / unidades altas iniciales

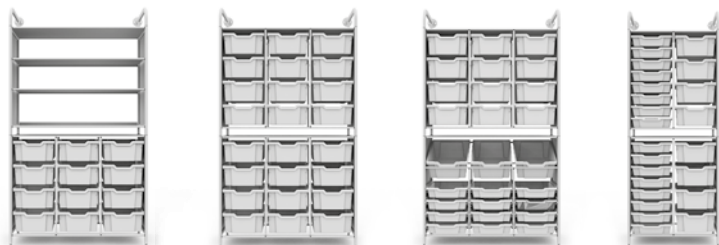

P32 - P42 : Additional tall units / unités hautes supplémentaires / unidades altas adicionales

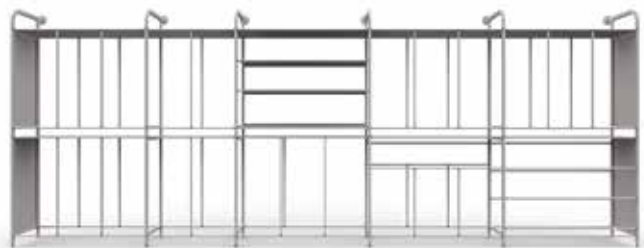

P43 : Supplementary information / Information supplémentaire / Información suplementaria

# Double column unit

Dimensions: 995(H) x 690(W) x 430mm(D)



CFRA44 x 1  
CFRF44 x 1  
CFRH44 x 1

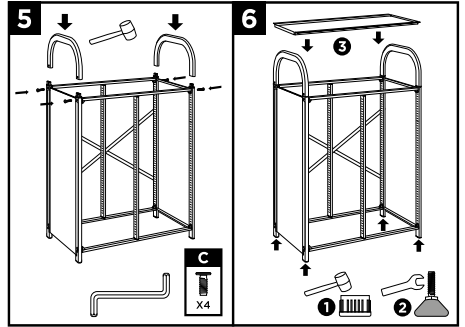
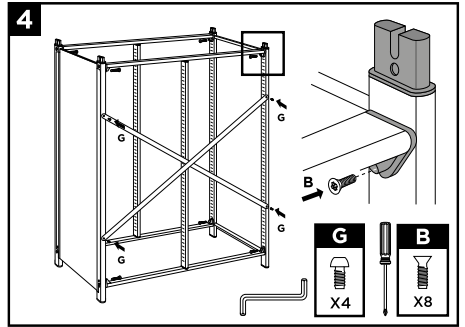
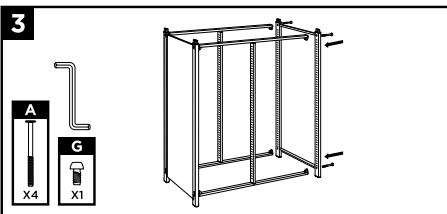
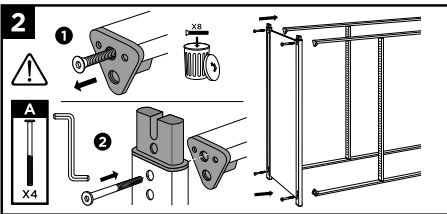
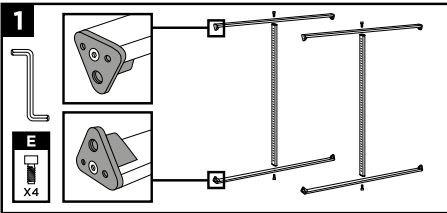
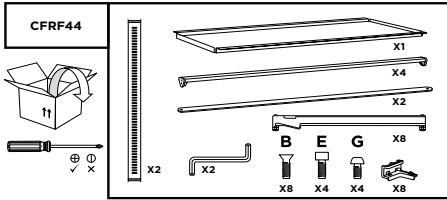
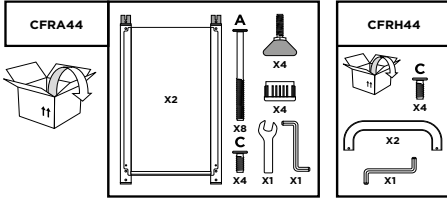

# Treble Column Unit

Dimensions: 995(H) x 1025(W) x 430mm(D)

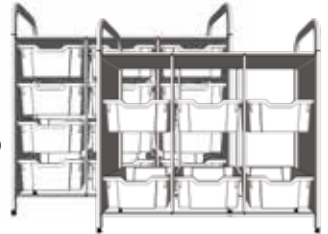

CF.....  
CFRF44 x 1  
CFRH44 x 1

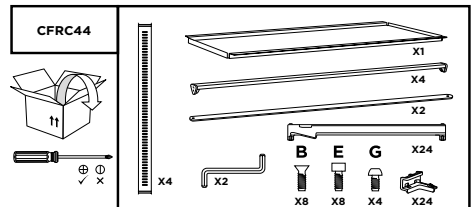
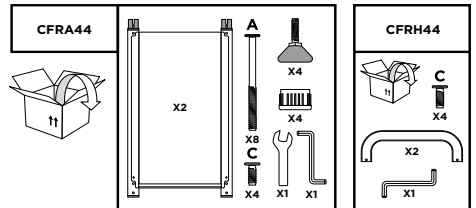



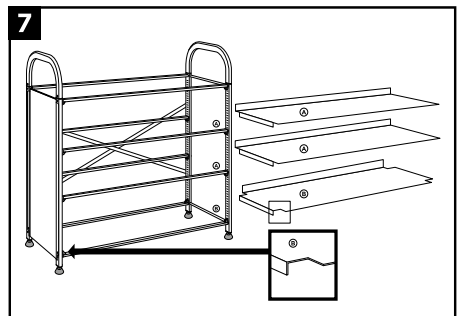
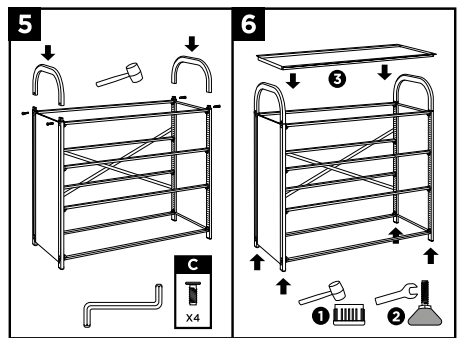
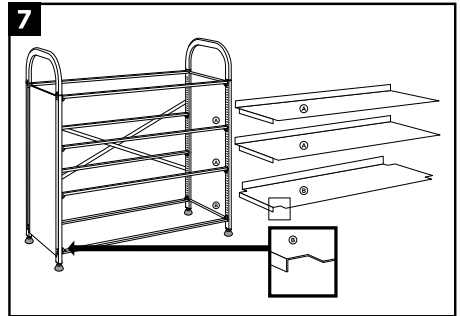
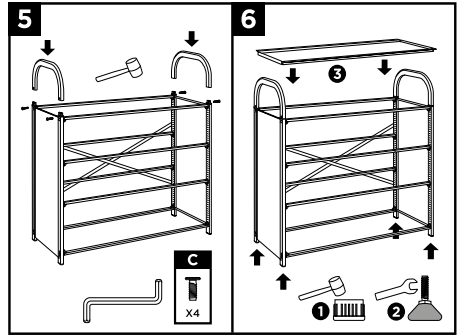
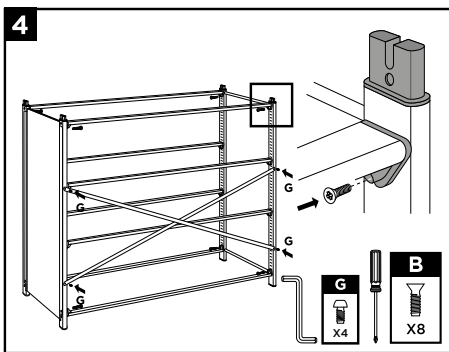
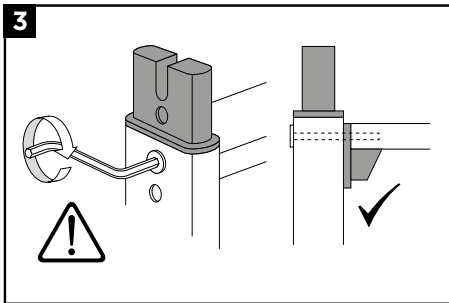
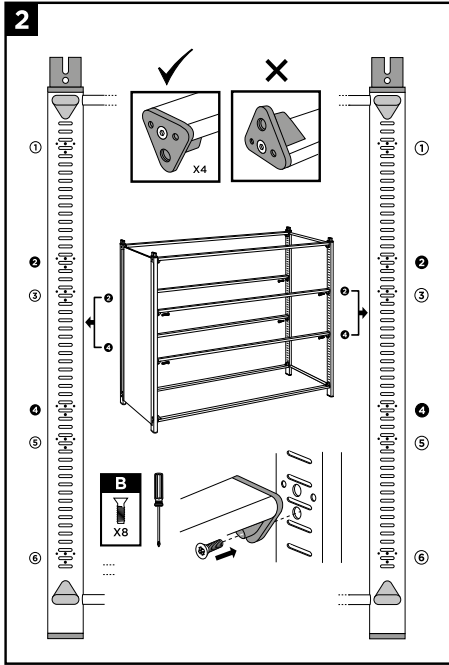





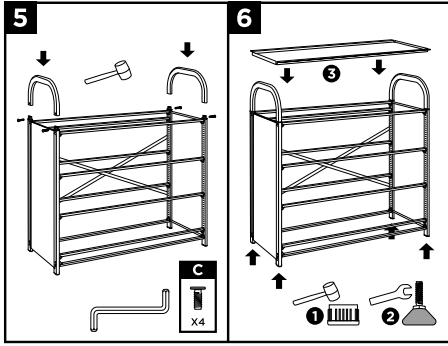

### Titled tray unit

Dimensions: 995(H) x 1025(W) x 430mm(D)

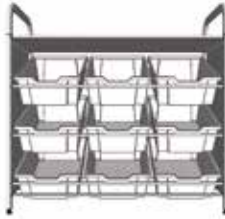

CFRA44 x 1  
 CFRE44 x 1  
 CFRH44 x 1

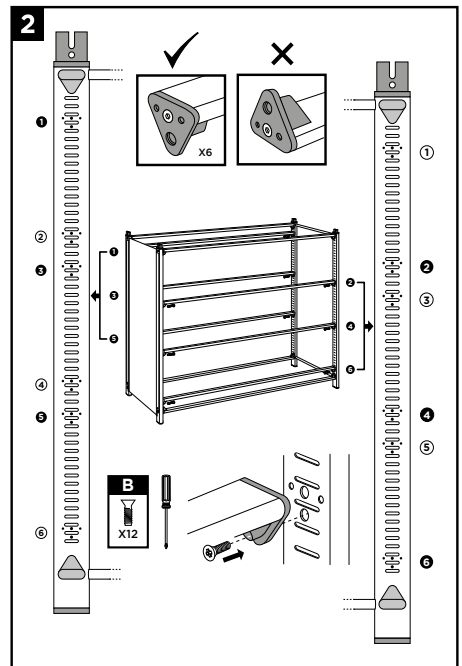
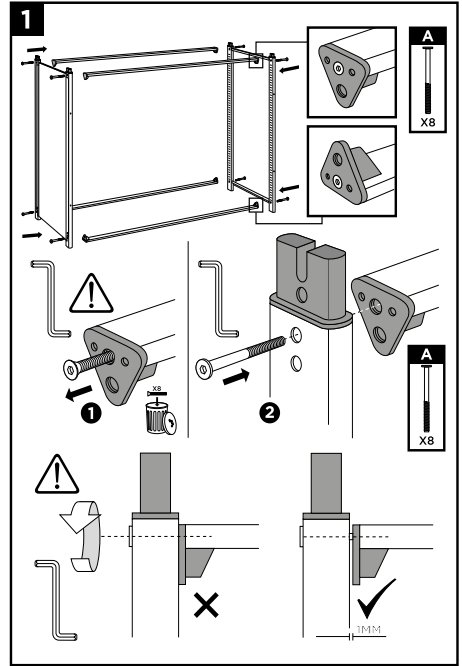
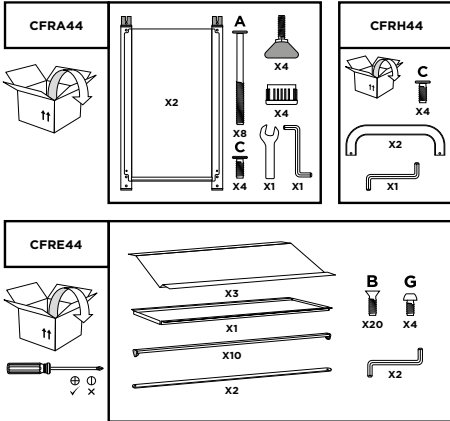

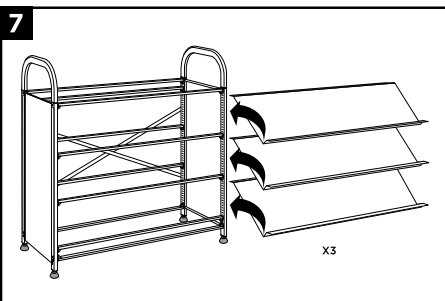
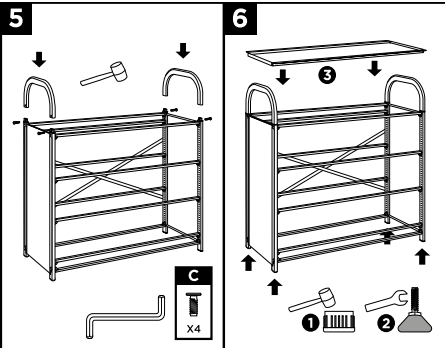
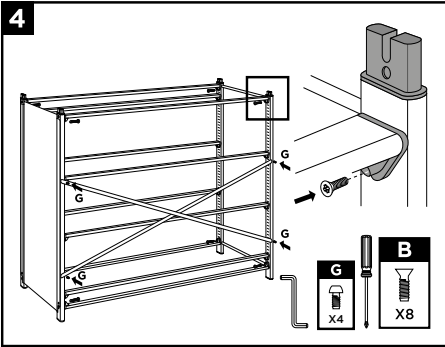
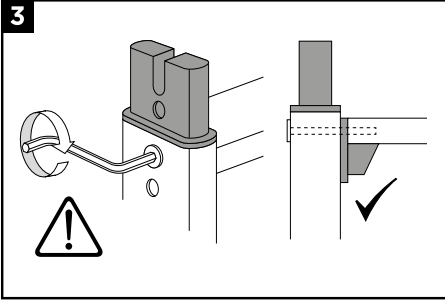

## Maker unit

Dimensions: 995(H) x 1025(W) x 430mm(D)

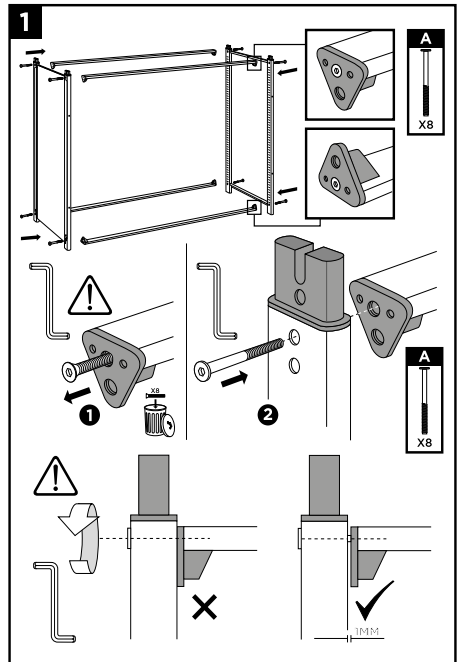
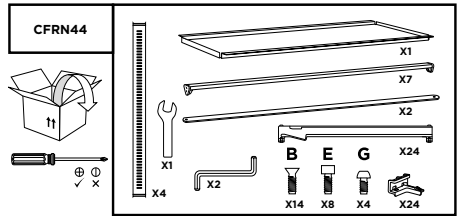
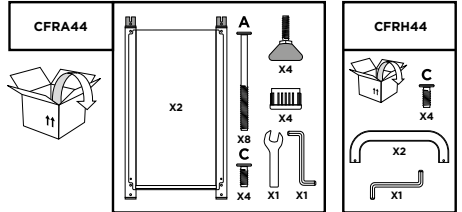

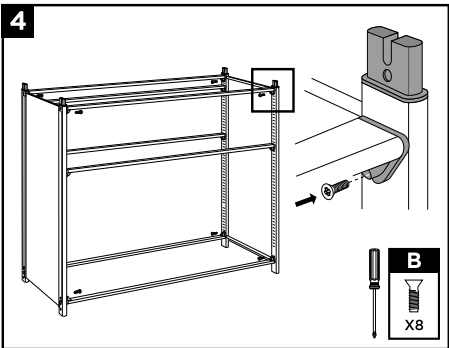
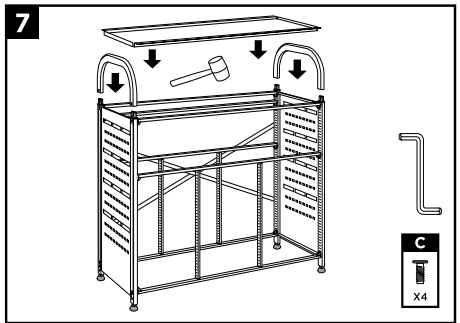
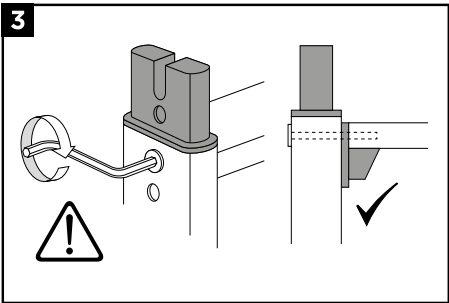
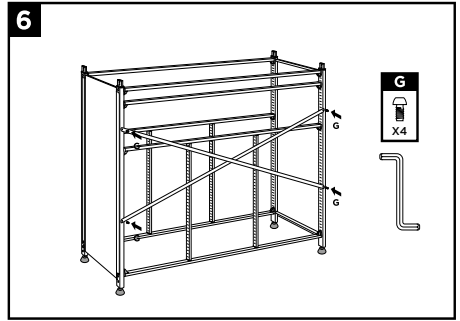
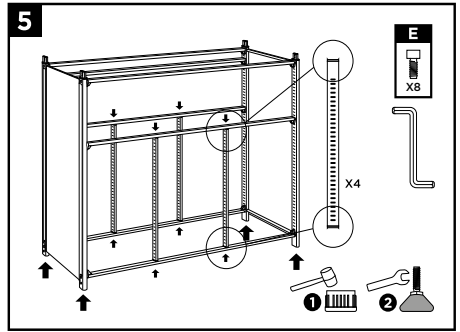
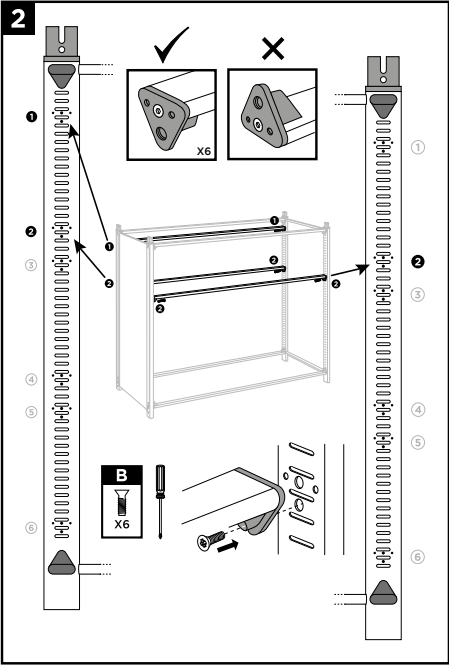

# Double column unit

Dimensions: 995(H) x 690(W) x 430mm(D)



**CFRB44 x 1**  
**CFRF44 x 1**

**CFRB44**

**CFRF44**

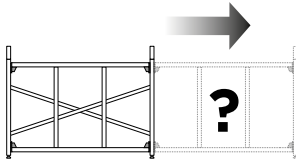

CFRIC44 CFRD44 CFR44 CFRF44 CFRH44 CFRW44

**1**

**2**

**3**

**4**

**5**

**6**

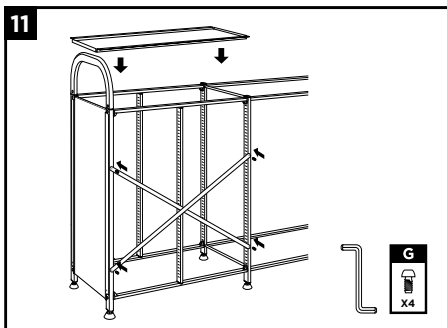
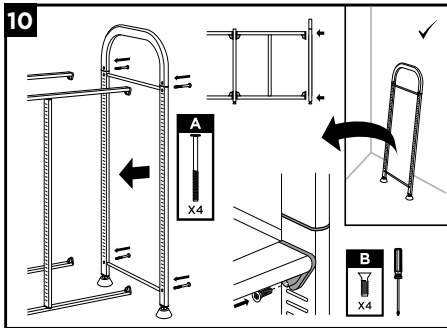
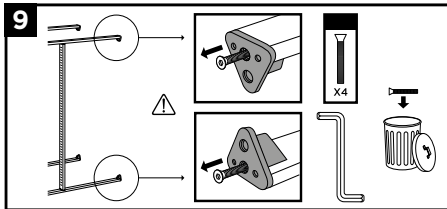
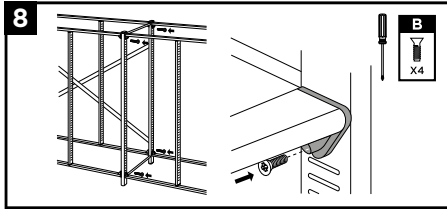
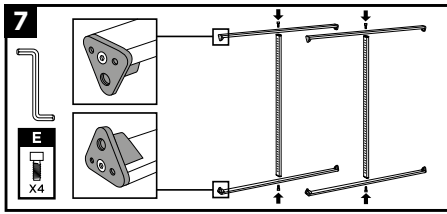

## Treble column unit

Dimensions: 995(H) x 1025(W) x 430mm(D)

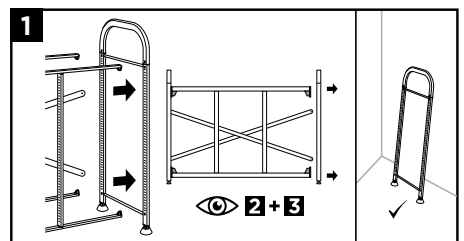
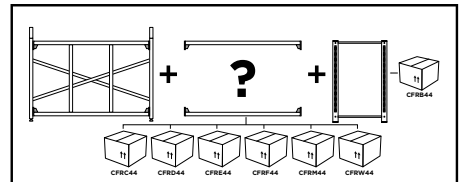
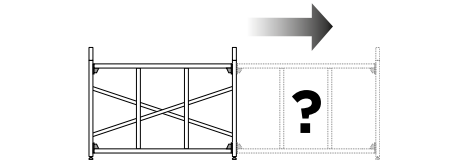
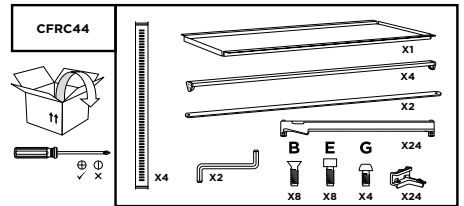
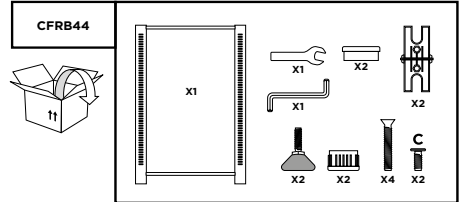
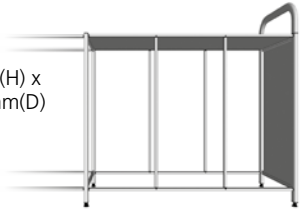

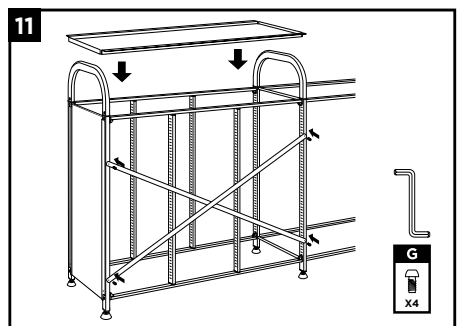
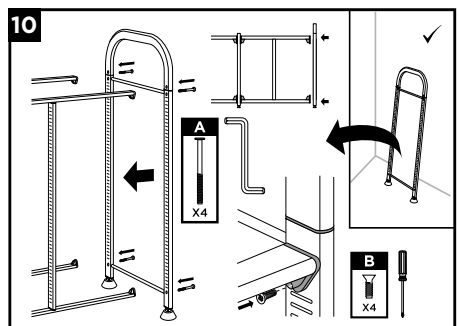
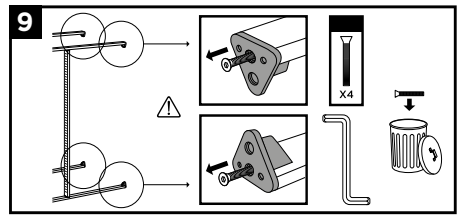
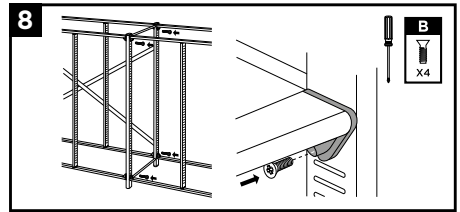
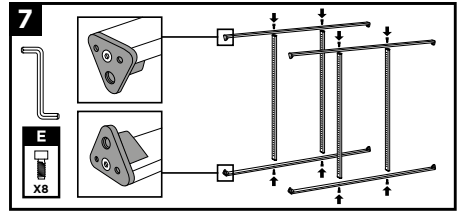
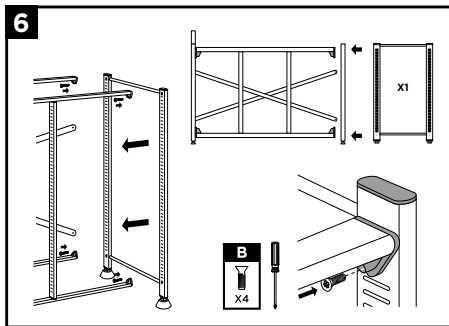
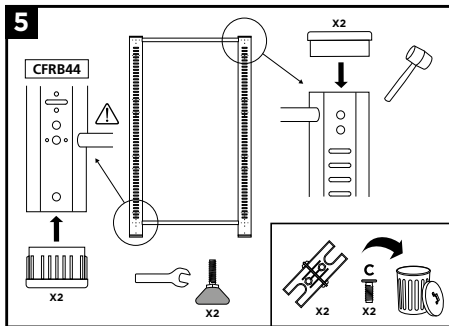
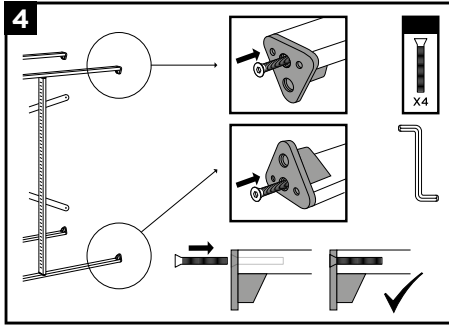
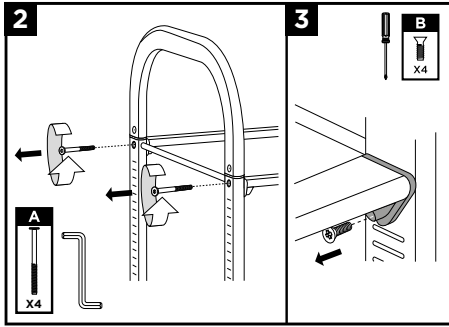



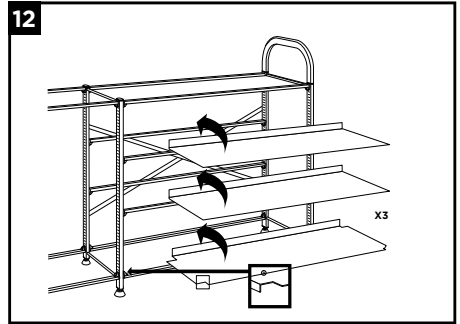
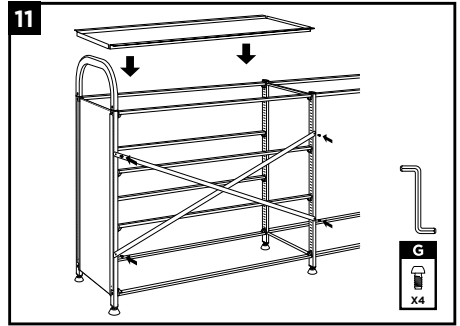
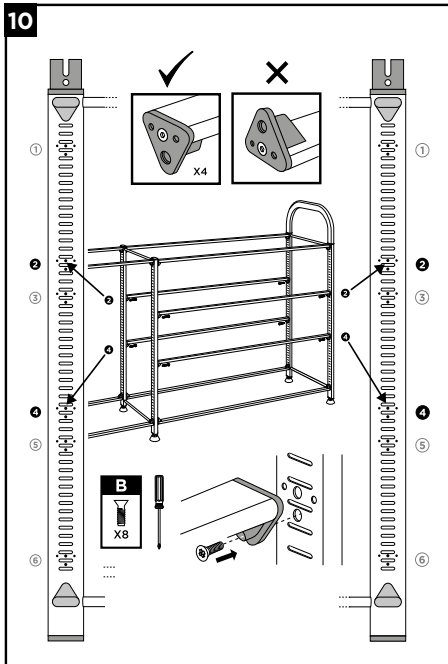
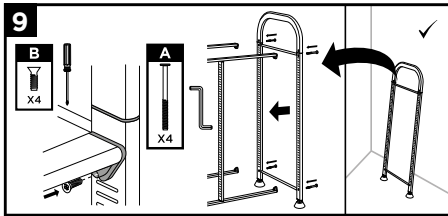
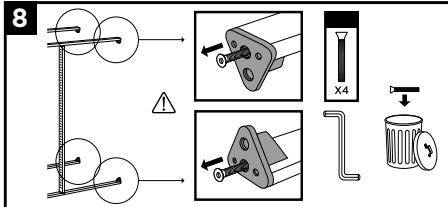
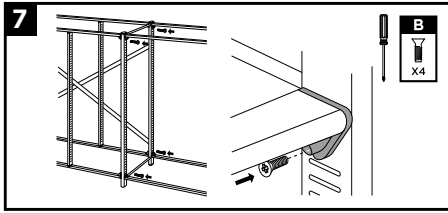

## Tilted tray unit

Dimensions: 995(H) x 1025(W) x 430mm(D)

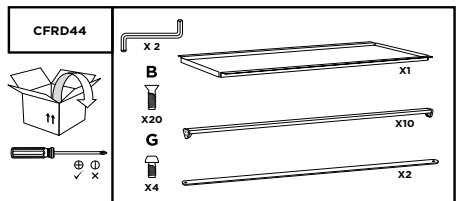
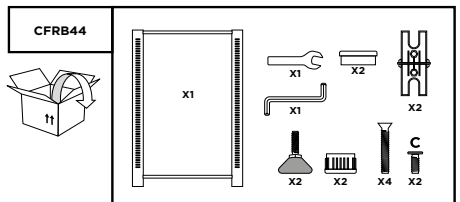
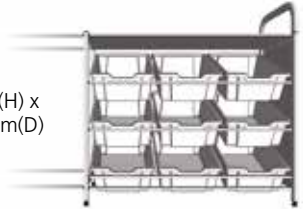



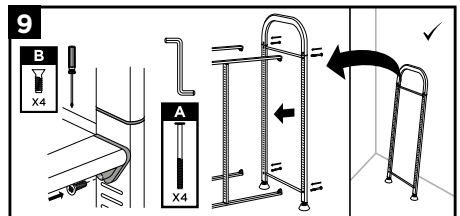
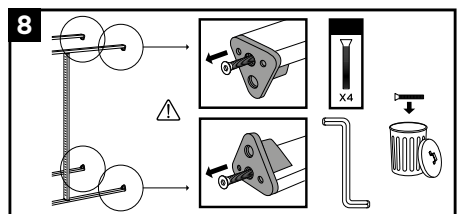
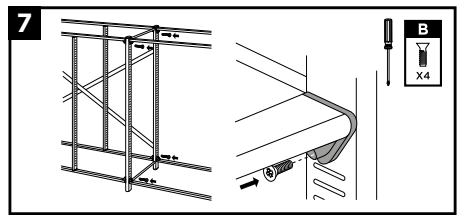
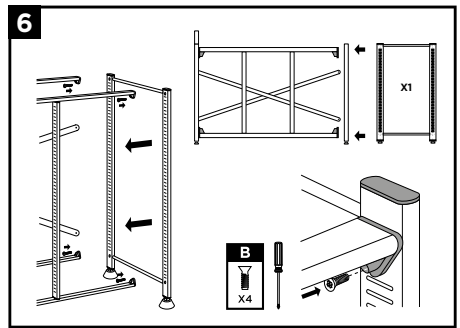
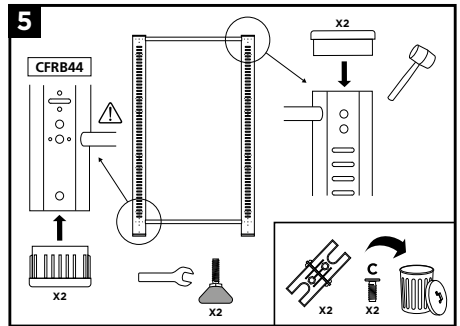
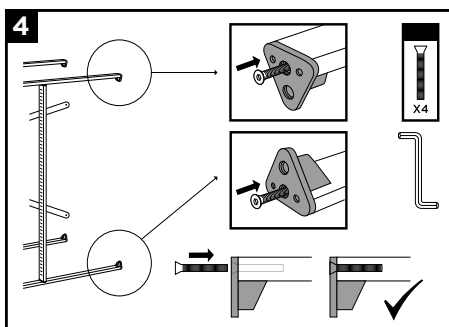
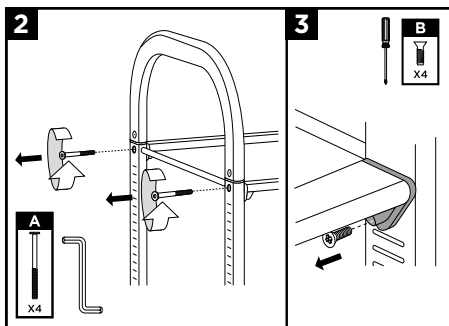
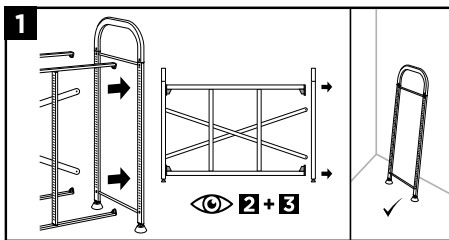
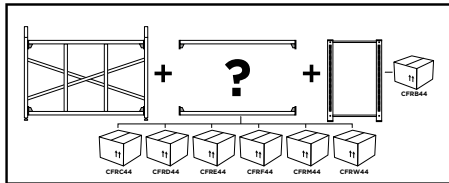
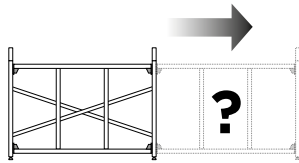

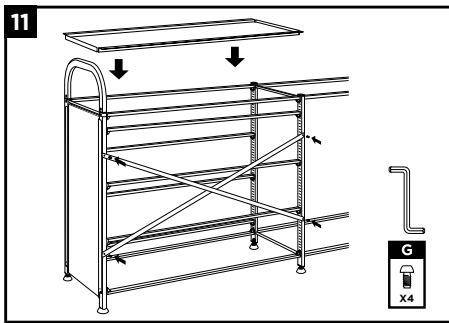
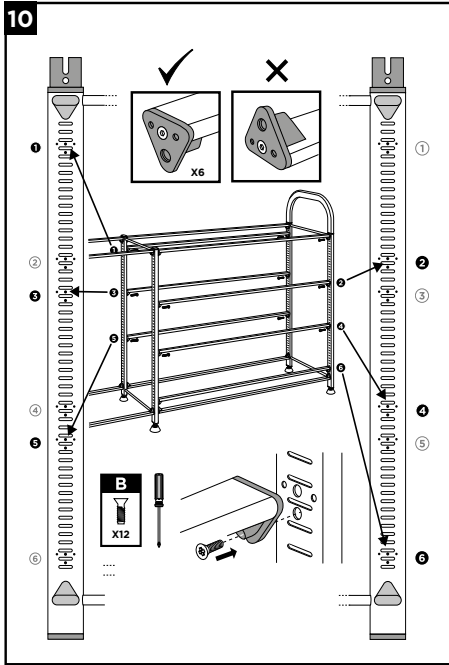

## Tilted shelf unit

Dimensions: 995(H) x 1025(W) x 430mm(D)

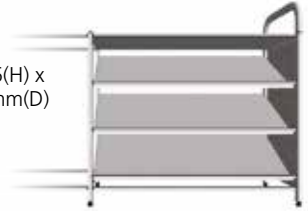

CFRB44 x 1  
CFRE44 x 1

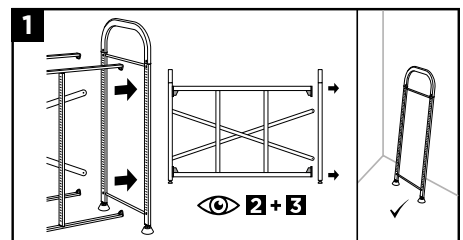
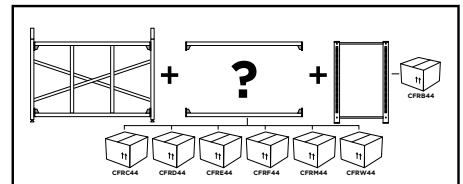
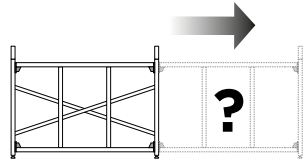
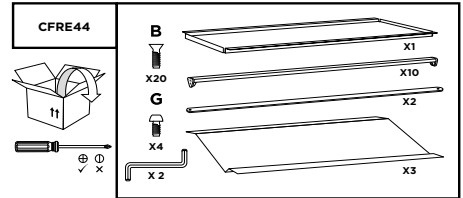
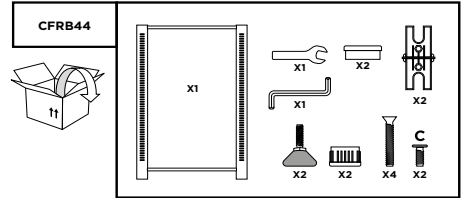

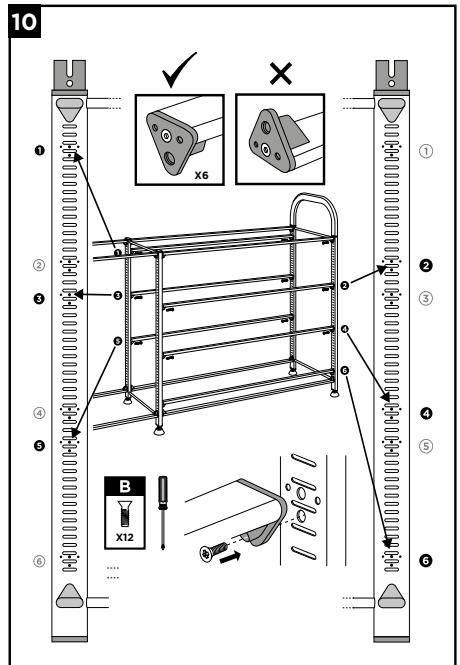
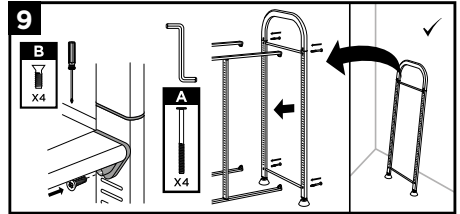
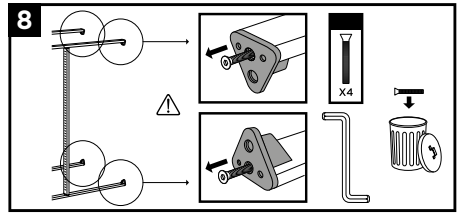
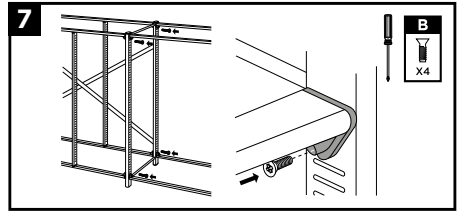
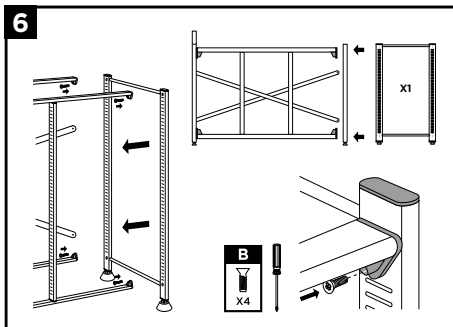
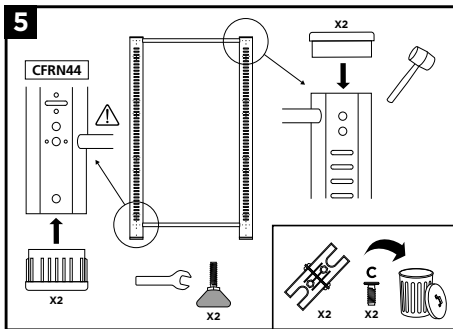
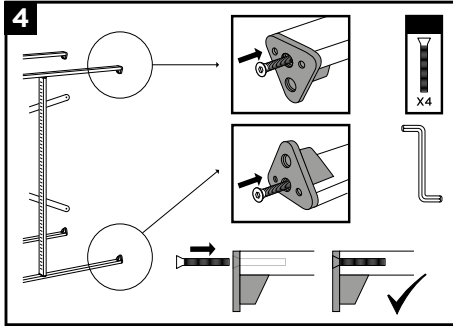
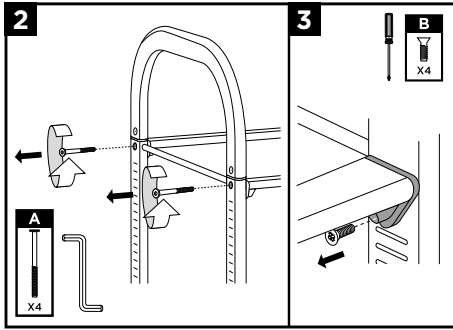

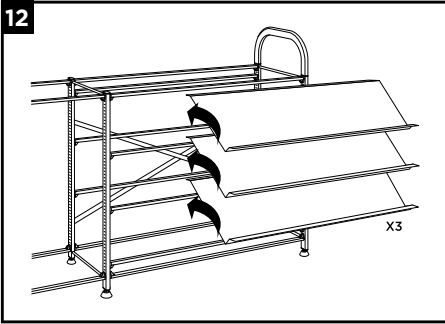
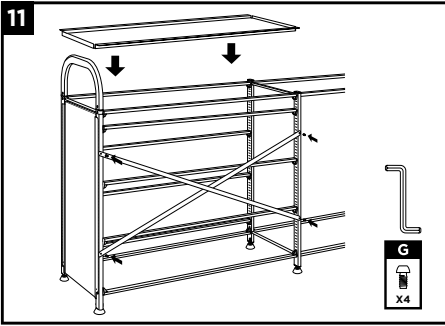

**Maker unit**

Dimensions: 995(H) x 1025(W) x 430mm(D)

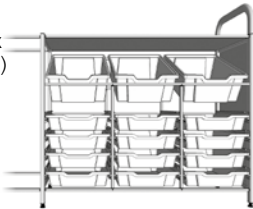

**1t** CFRB44 x 1  
CFRN44 x 1

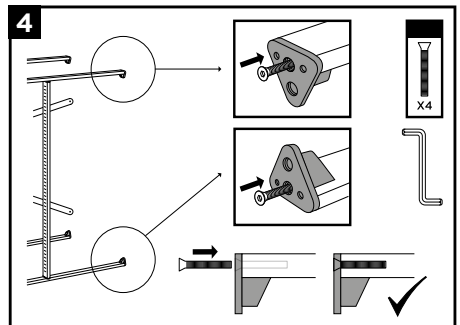
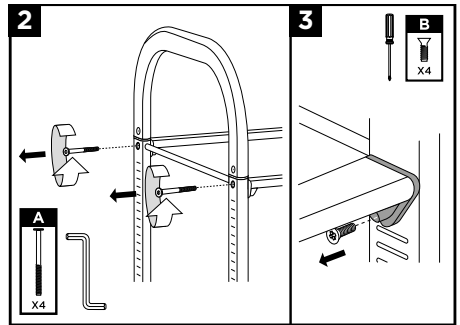
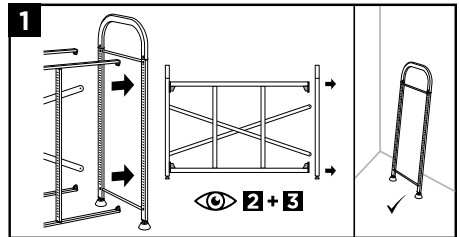
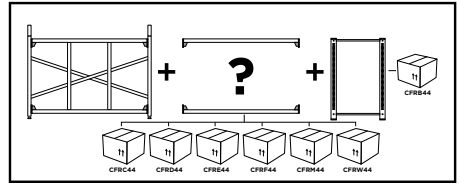
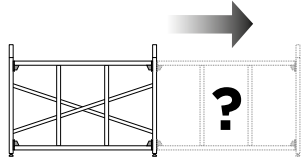
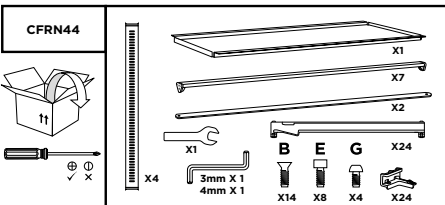
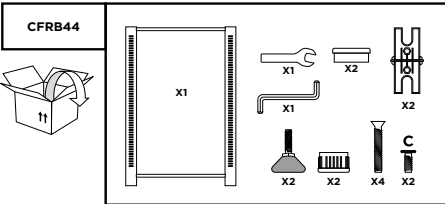

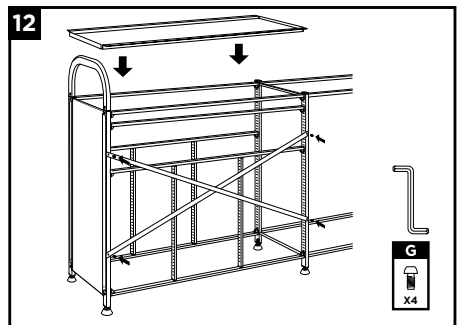
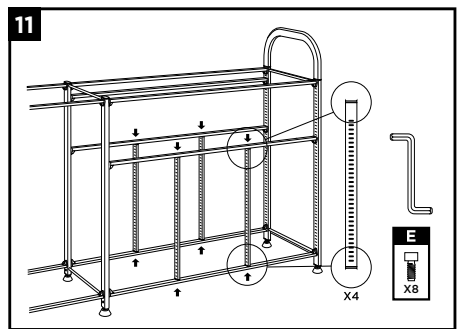
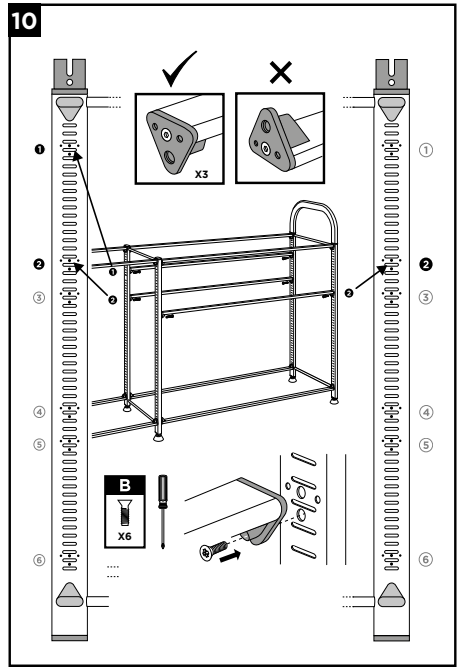
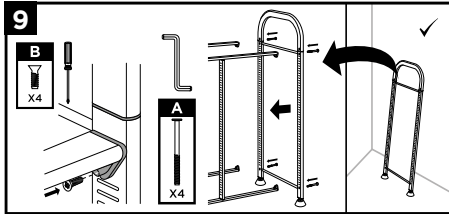
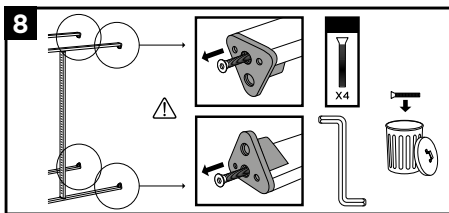
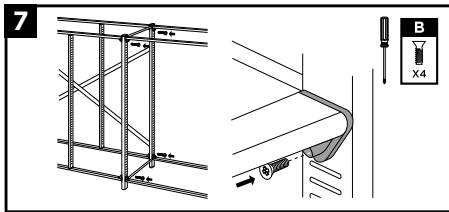
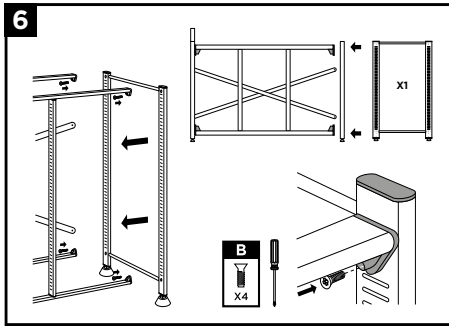
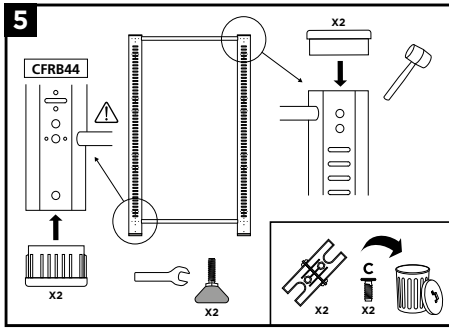

# Low adder workstation

Dimensions: 995(H) x 690(W) x 430mm(D)



1  
CFRB44 x 1  
CFRW44 x 1

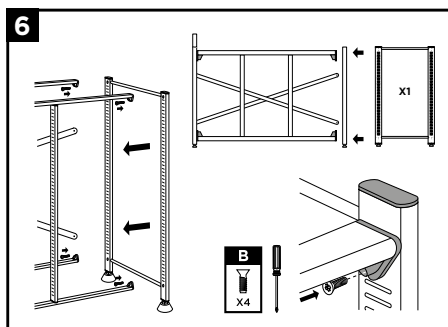
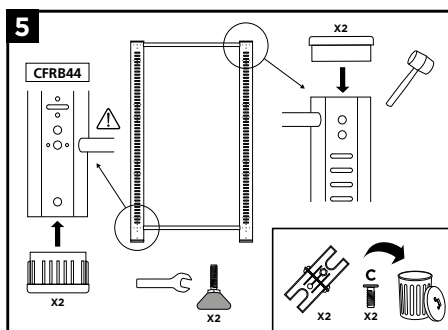
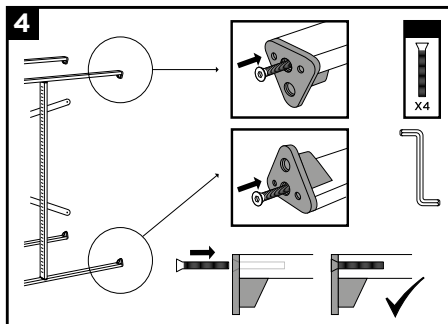
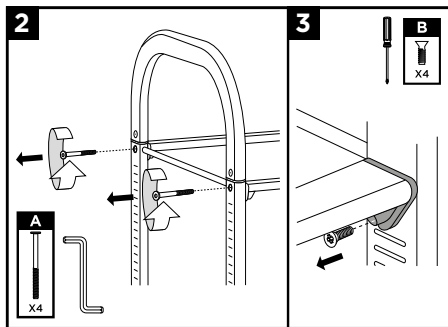
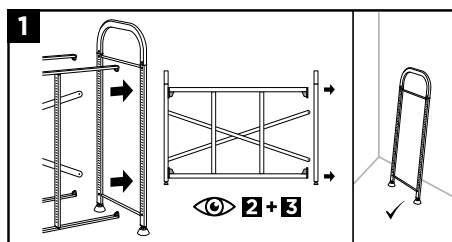
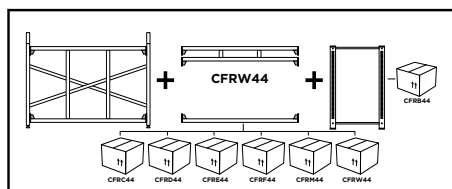
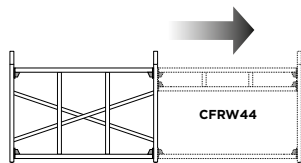
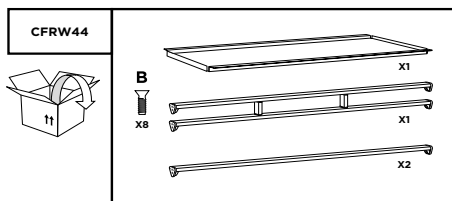
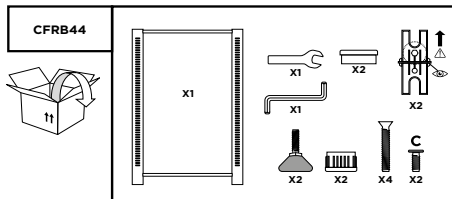

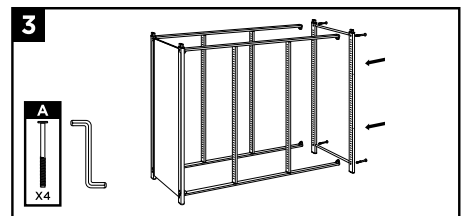
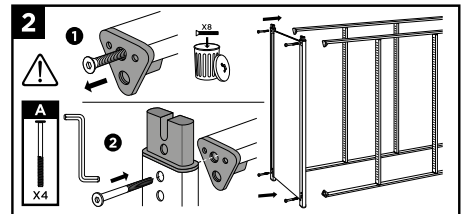
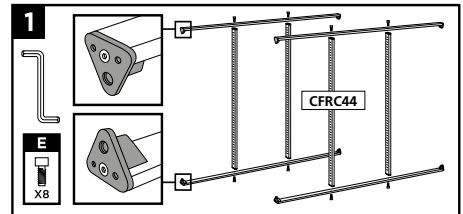
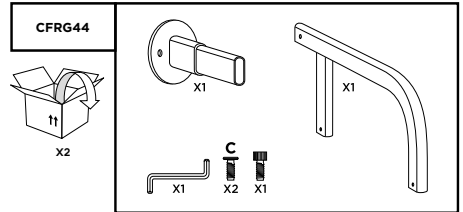
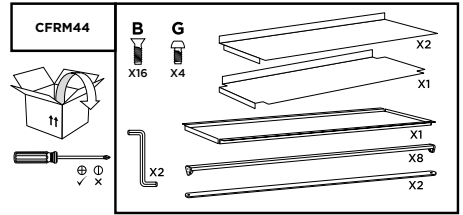
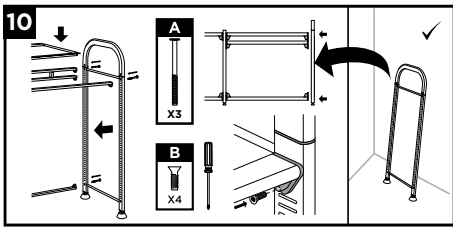
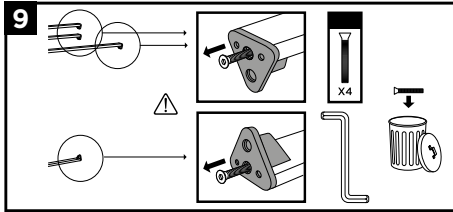
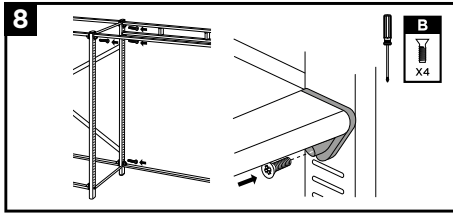

## Display-store unit

Dimensions: 1806(H) x  
1025(W) x 430mm(D)



1t  
CFRA44 x 2  
CFRC44 x 1  
CFRM44 x 1  
CFRG44 x 2

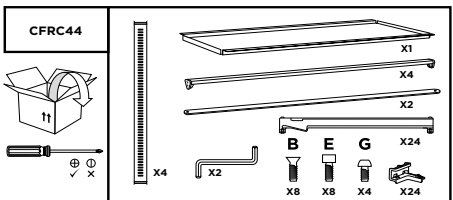
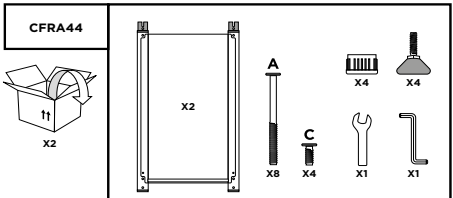

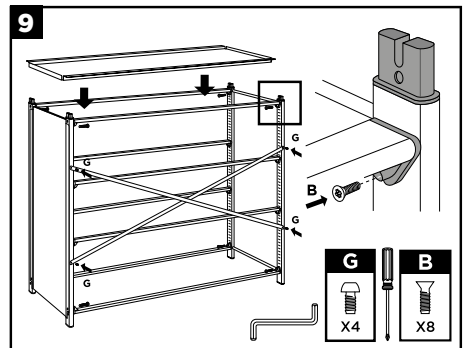
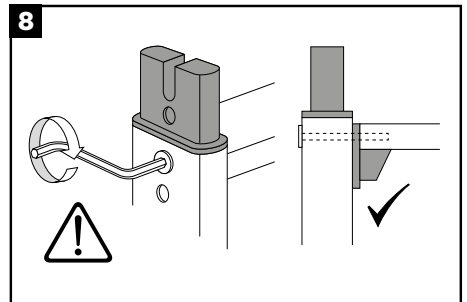
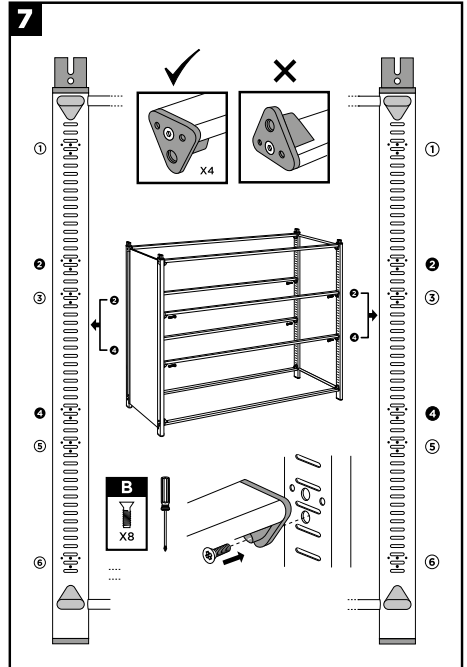
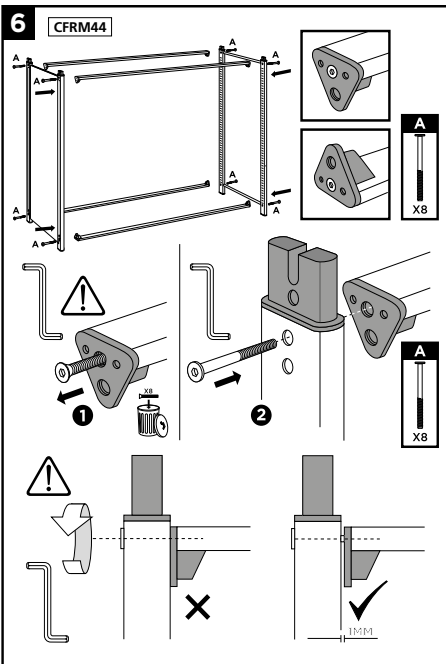
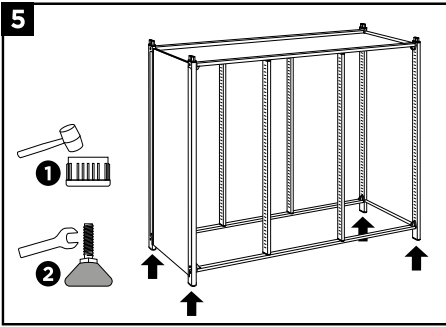
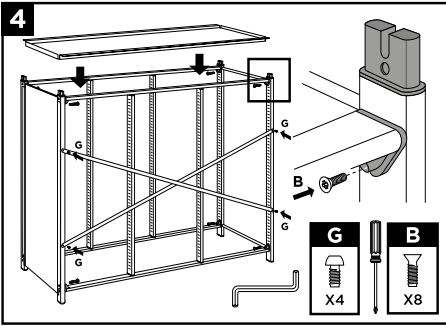



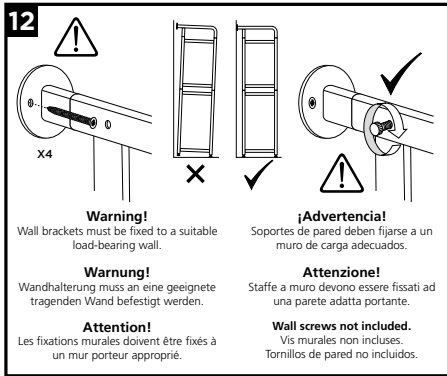
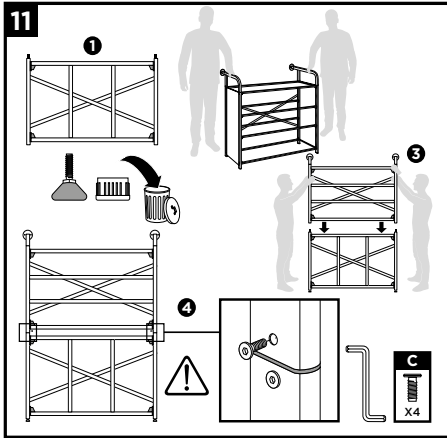
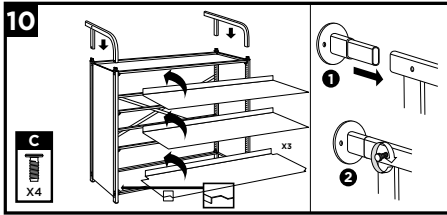

## Tall-store unit and Flexi-store unit

Dimensions: 1806(H) x  
1025(W) x 430mm(D)

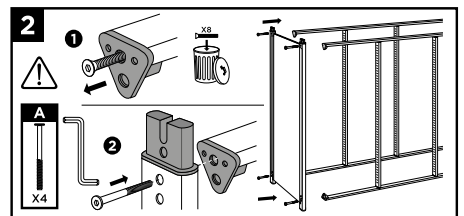
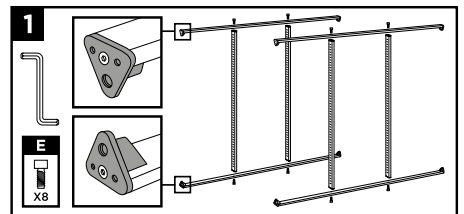
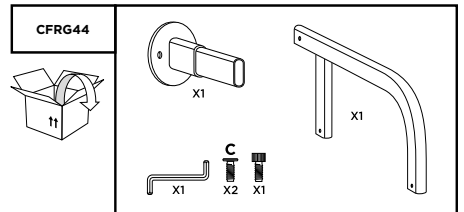
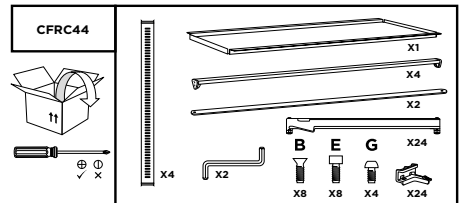
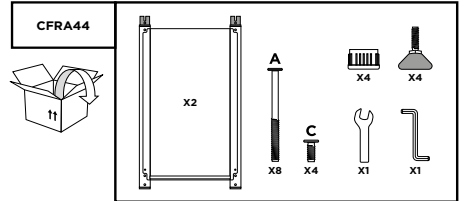

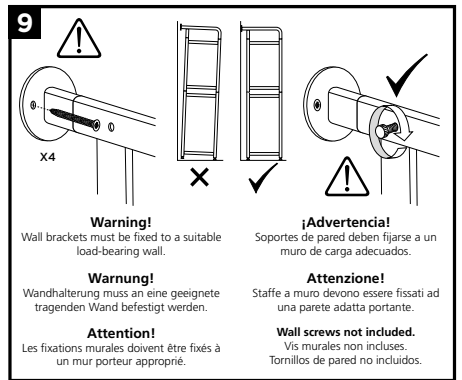
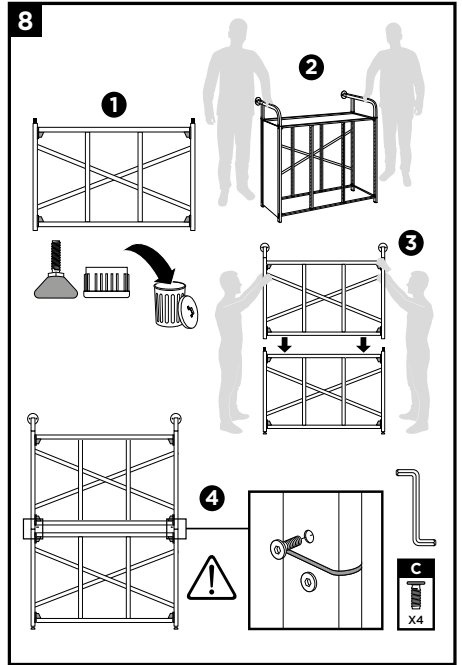
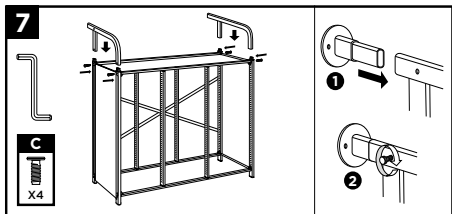
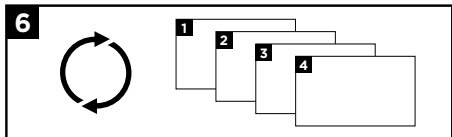
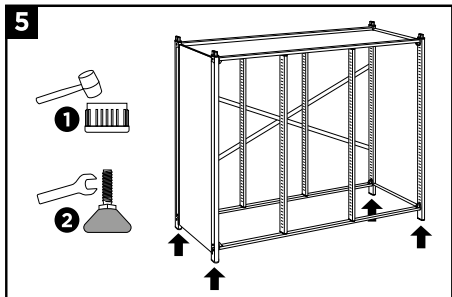
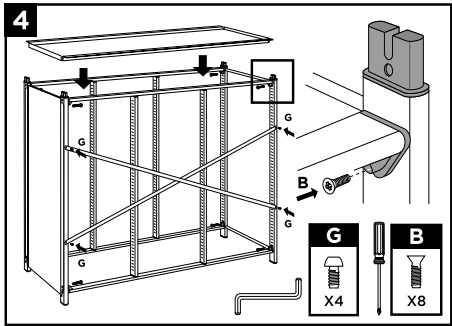
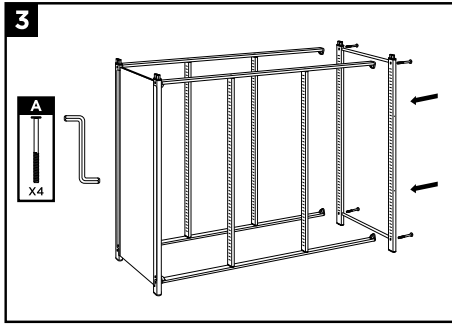

# Maker-store unit and Maker-tall unit

Dimensions: 1806(H) x  
1025(W) x 430mm(D)



CFRA44 x 2  
CFRC44 x 1  
CFRG44 x 2  
CFRN44 x 1

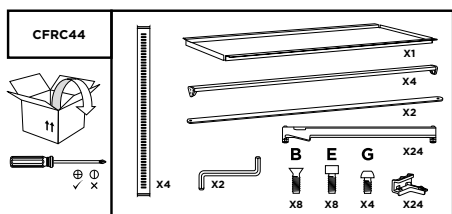
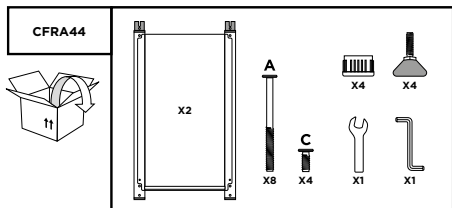

CFRA44 x 2  
CFRC44 x 1  
CFRG44 x 2  
CFRN44 x 1

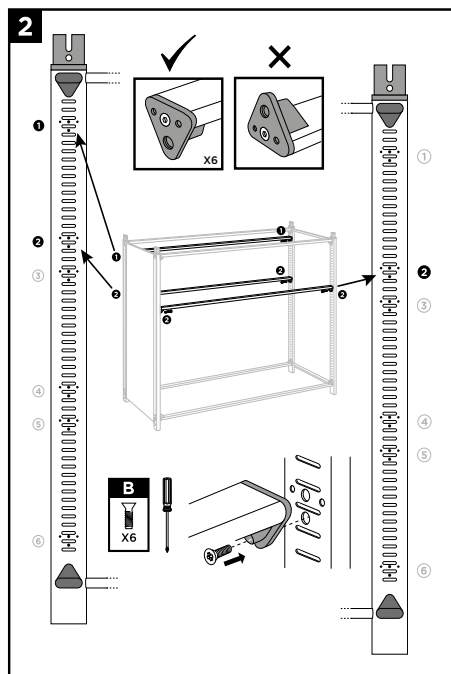
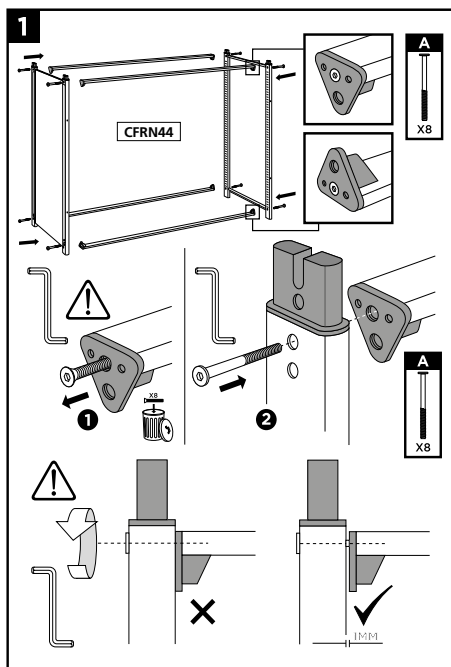
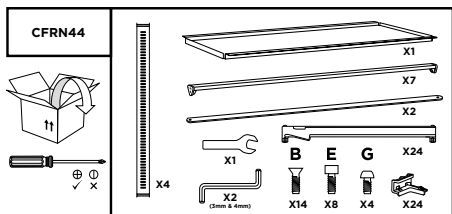
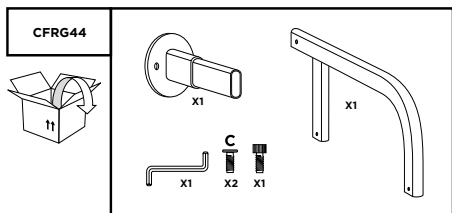

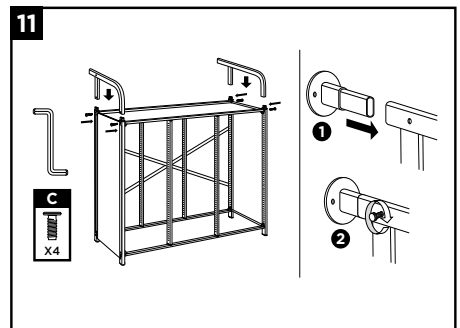
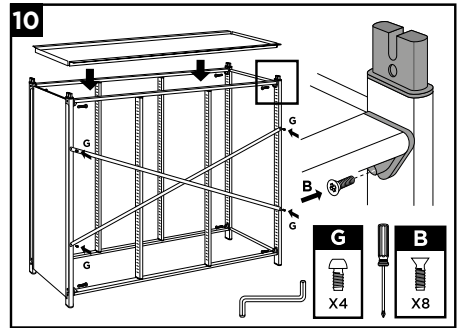
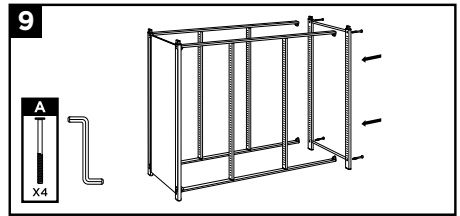
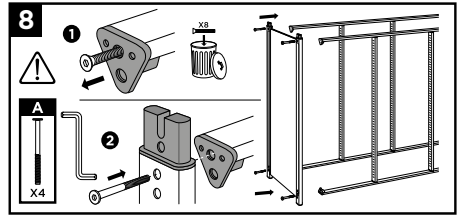
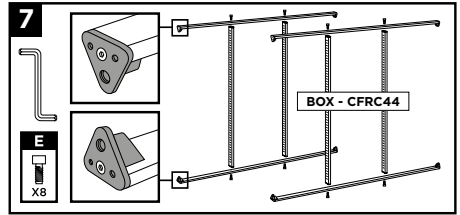
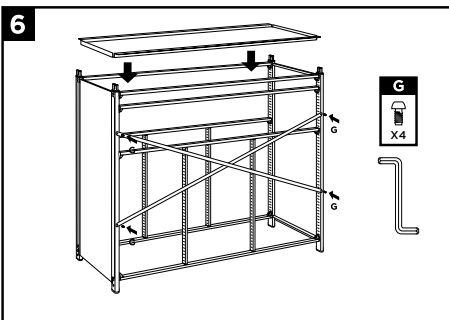
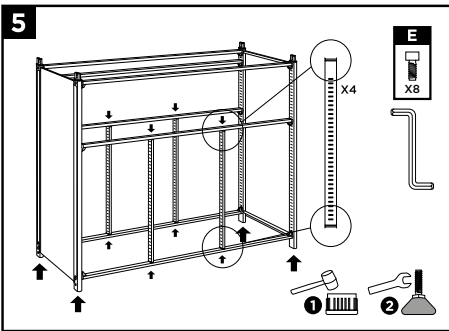
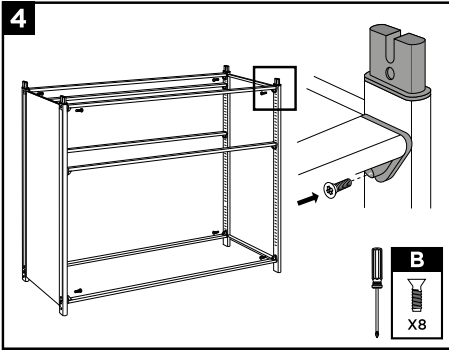
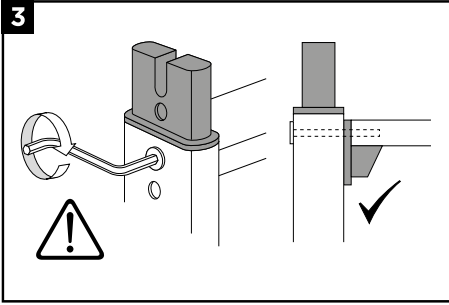

12

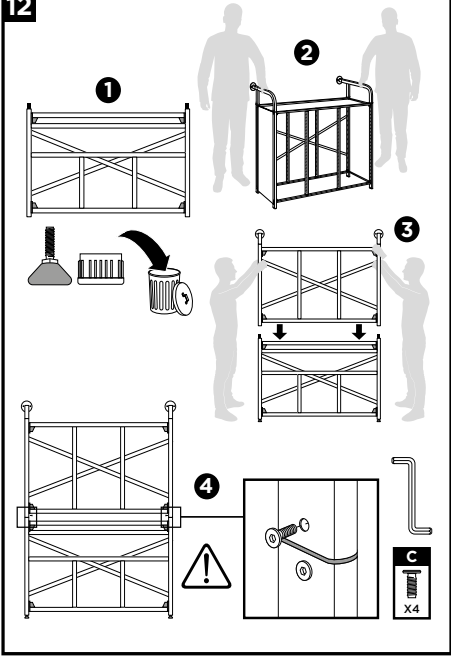

13

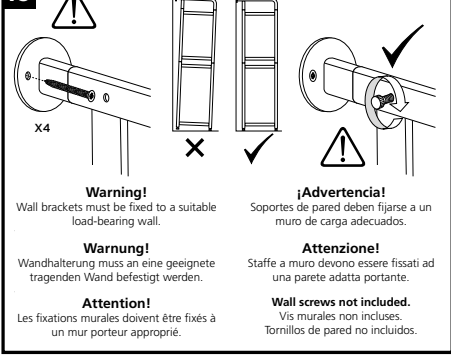

### Pick-store unit

Dimensions: 1806(H) x 1025(W) x 430mm(D)



- CFRA44 x 2
- CFRC44 x 1
- CFRD44 x 1
- CFRG44 x 2

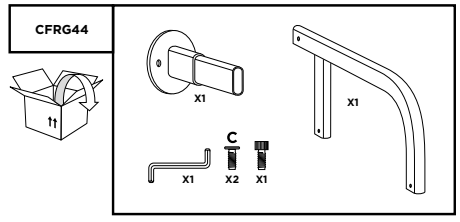
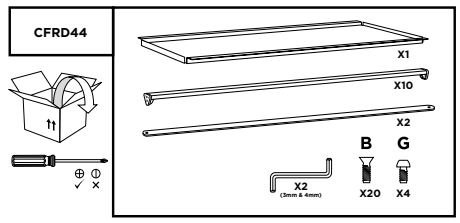
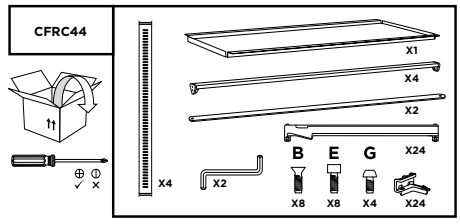
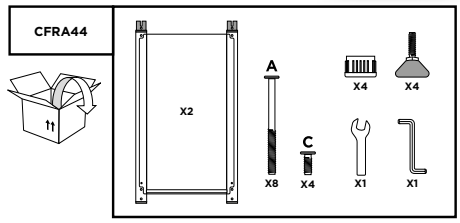

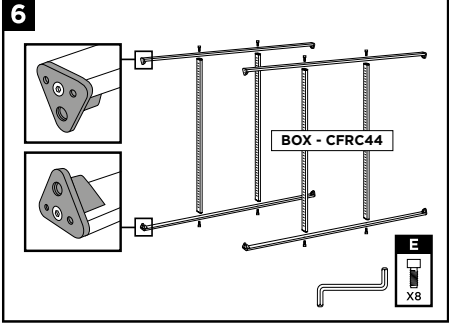
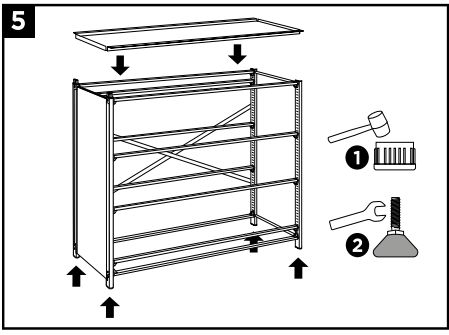
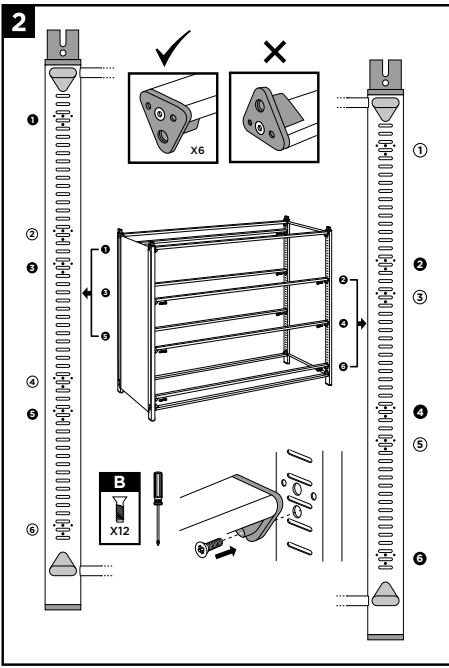
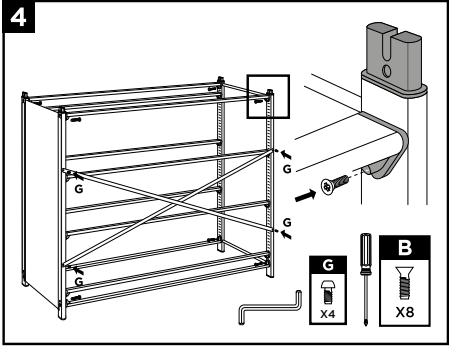
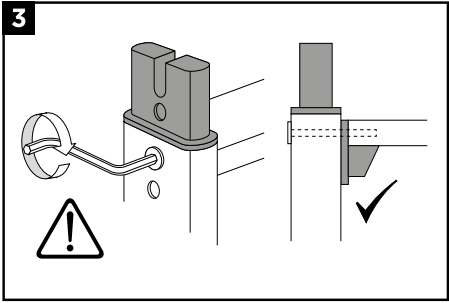
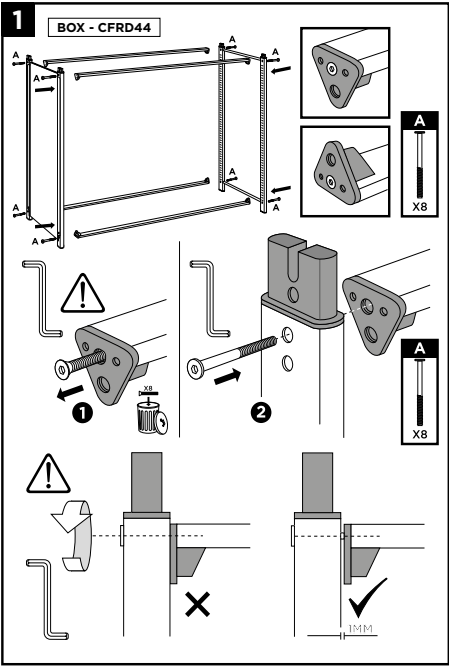

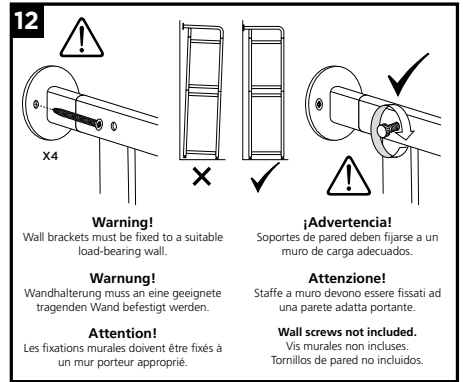
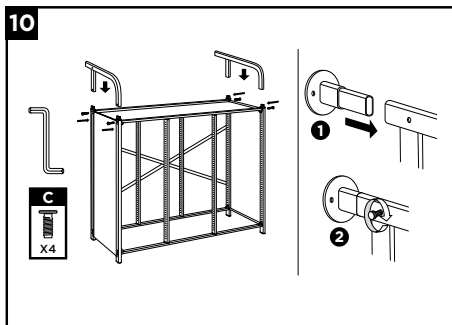
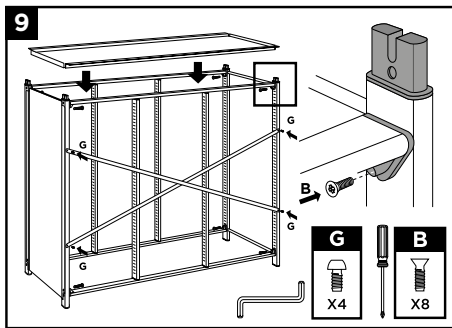
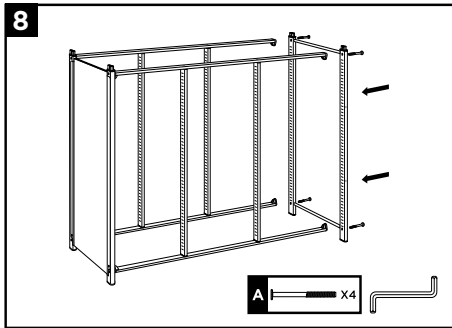
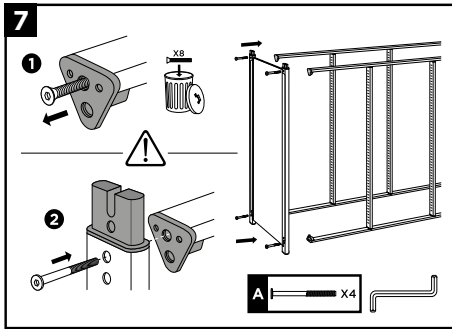

## Slim-store unit

Dimensions: 1806(H) x 695(W) x 430mm(D)

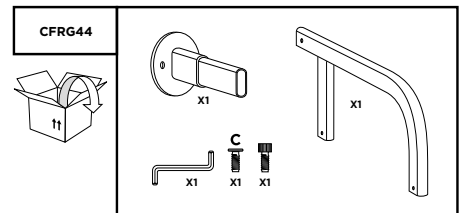
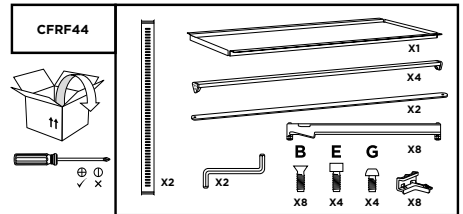
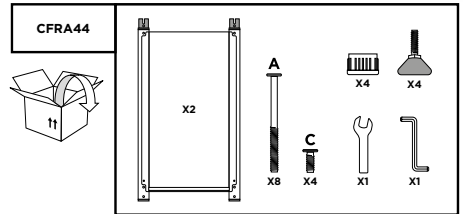

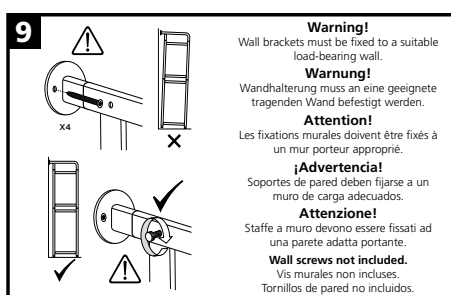
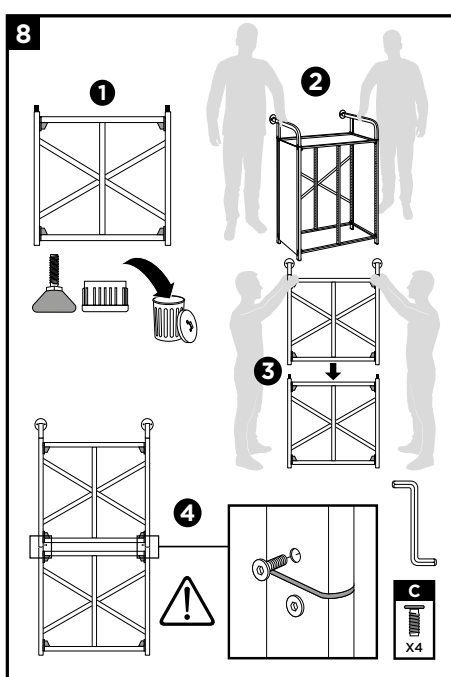
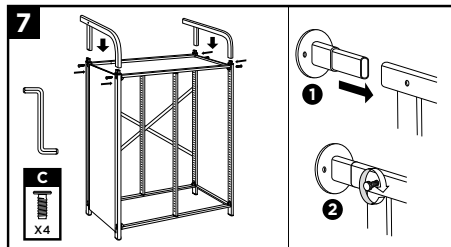
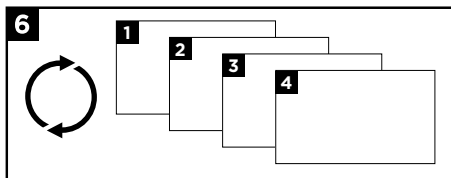
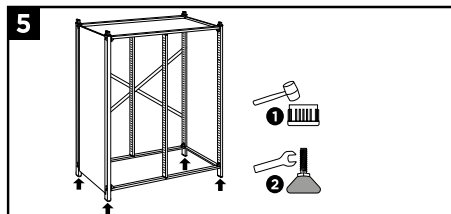
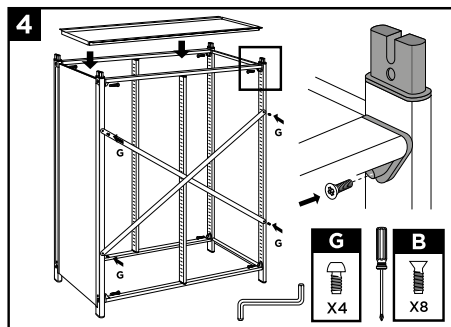
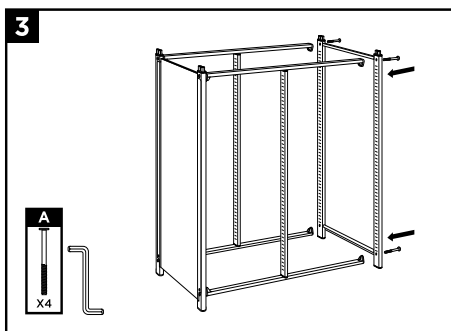
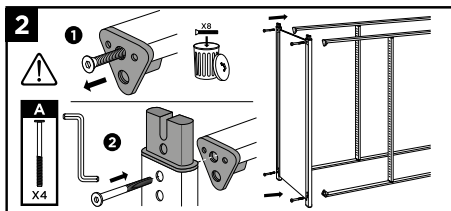
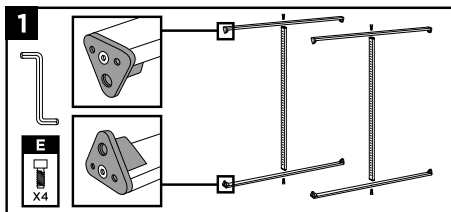



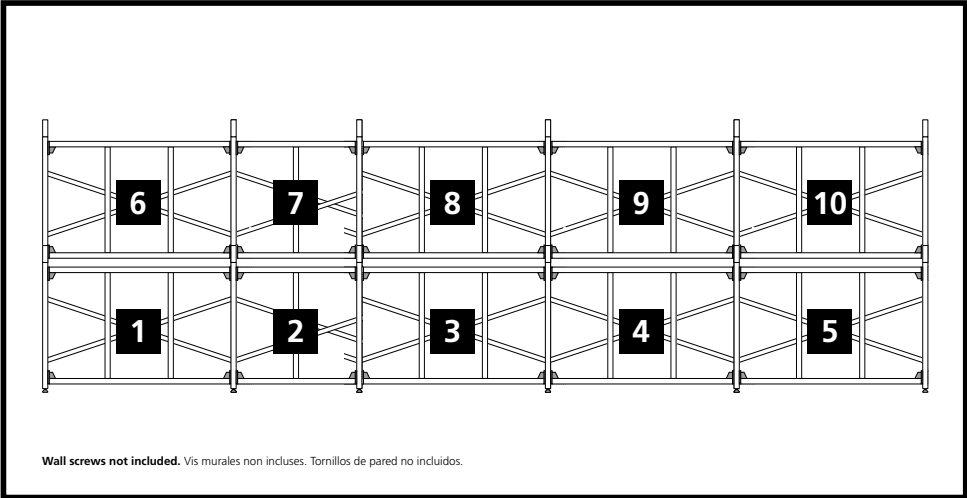
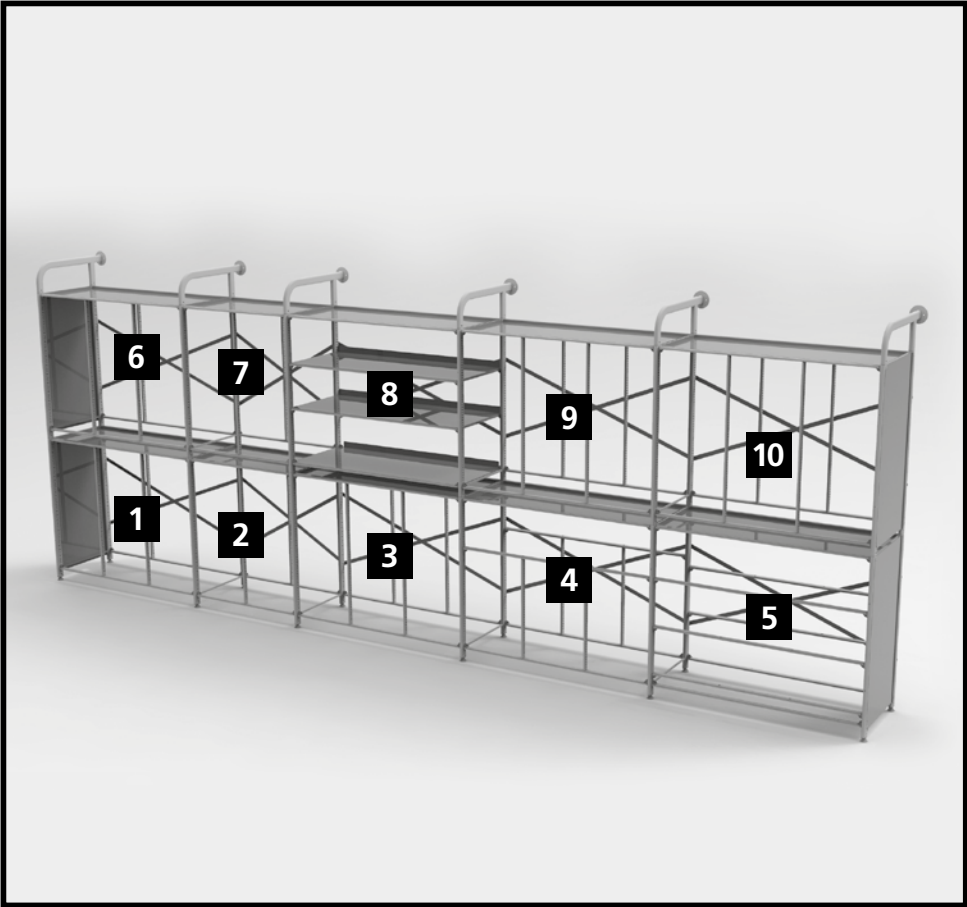

Wall screws not included. Vis murales non incluses. Tornillos de pared no incluidos.

# 1. Treble column unit

CFRA44 + CFRC44  
+ CFRB44

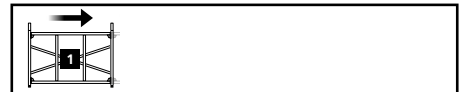
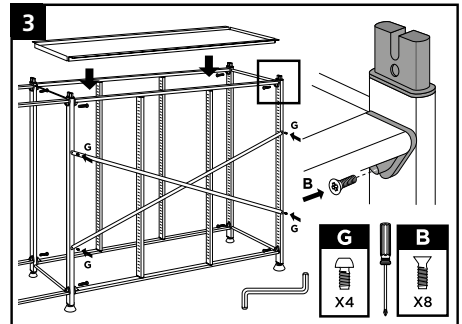
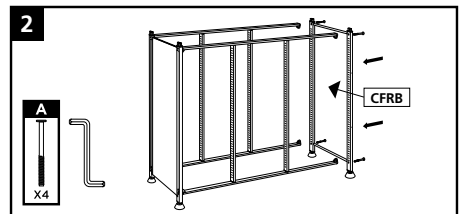
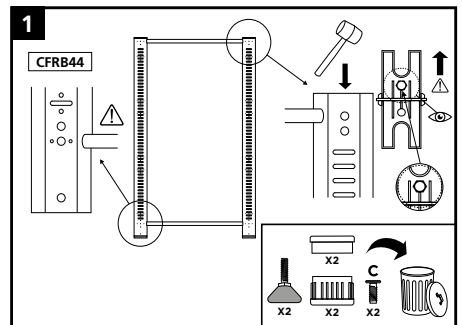
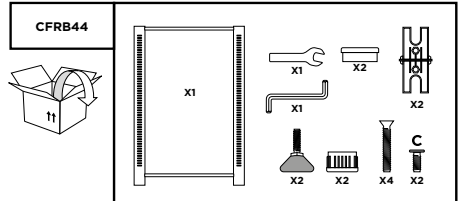
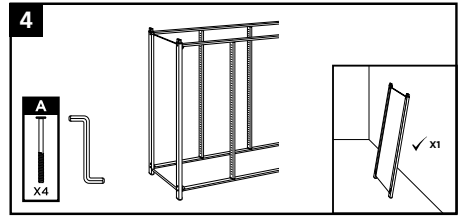
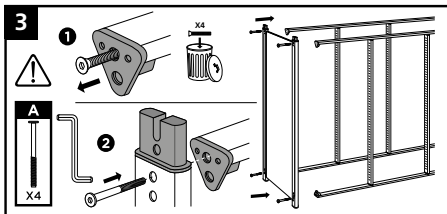
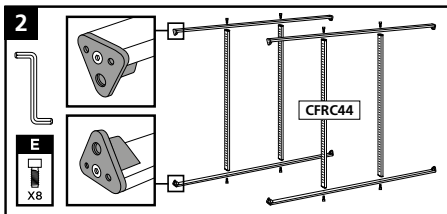
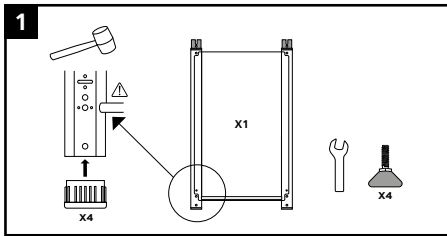
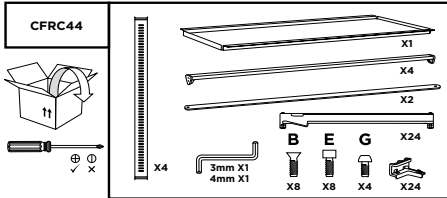
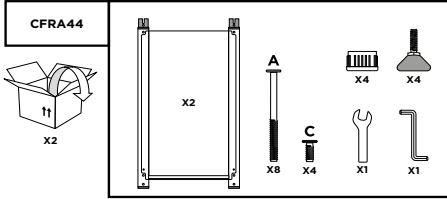

## 2. Double column

CFRF44 + CFRB44

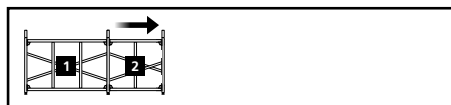
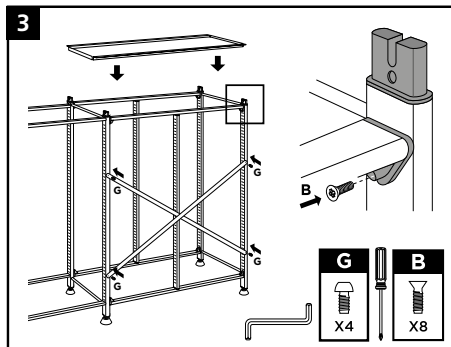
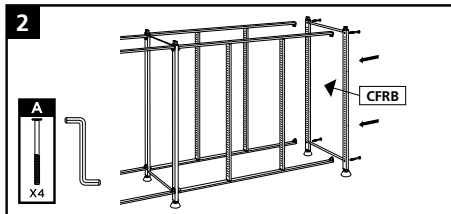
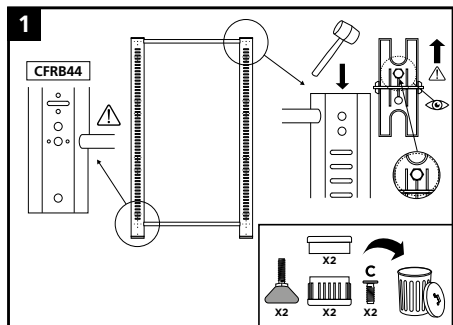
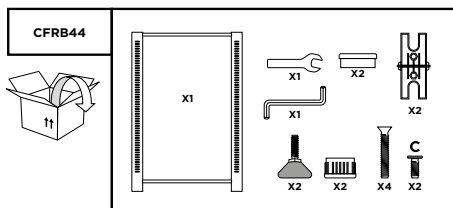
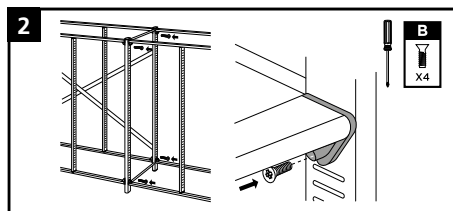
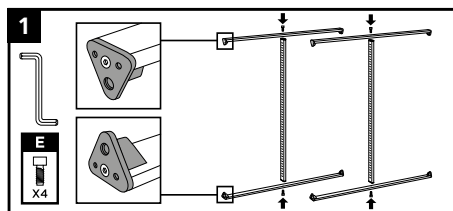
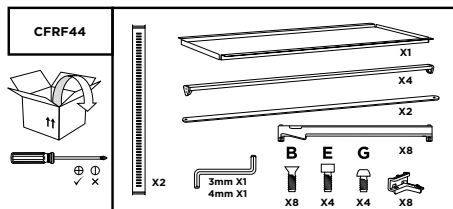

## 3. Treble column unit

CFRC44 + CFRB44

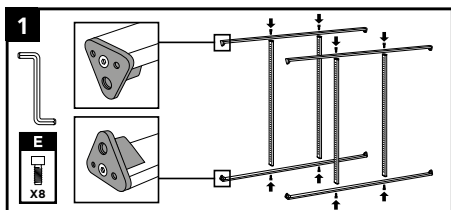
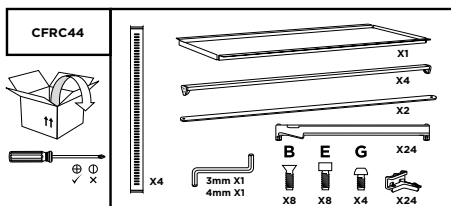

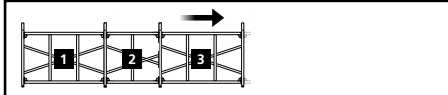
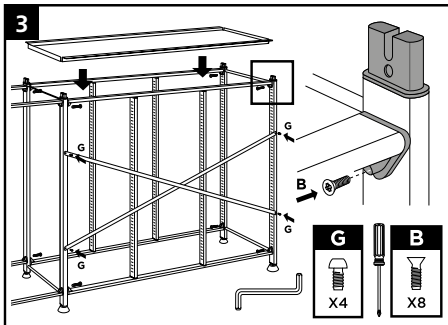
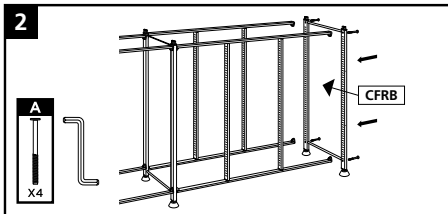
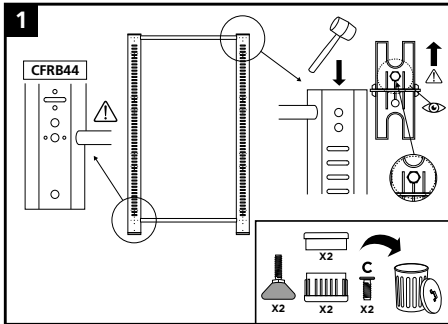
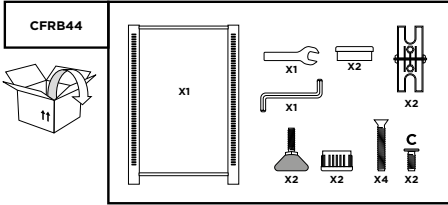
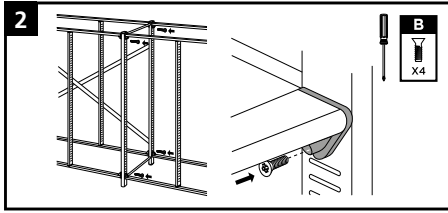

## 4. Maker unit

CFRN44 + CFRB44

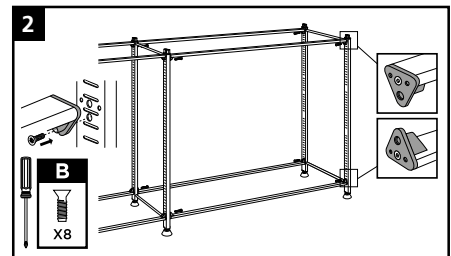
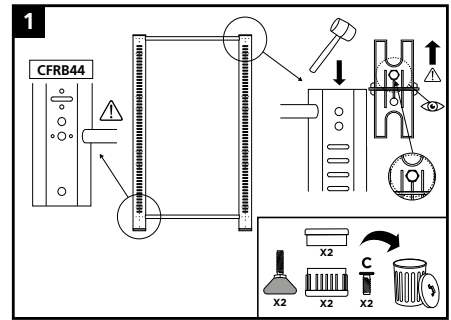
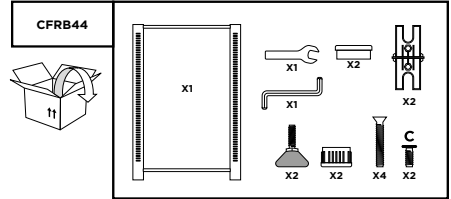
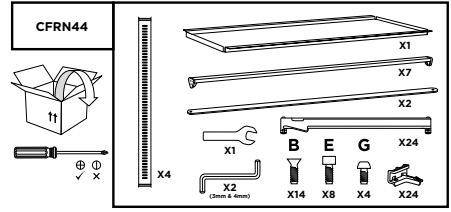
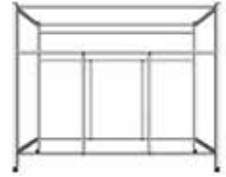

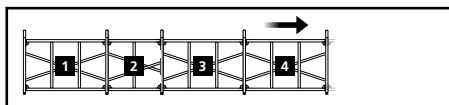
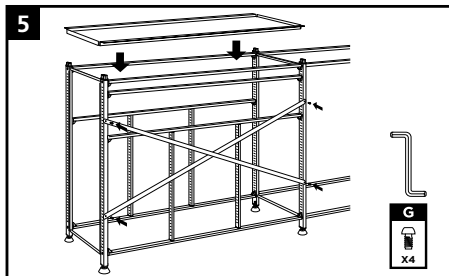
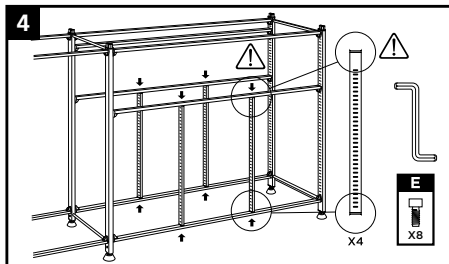
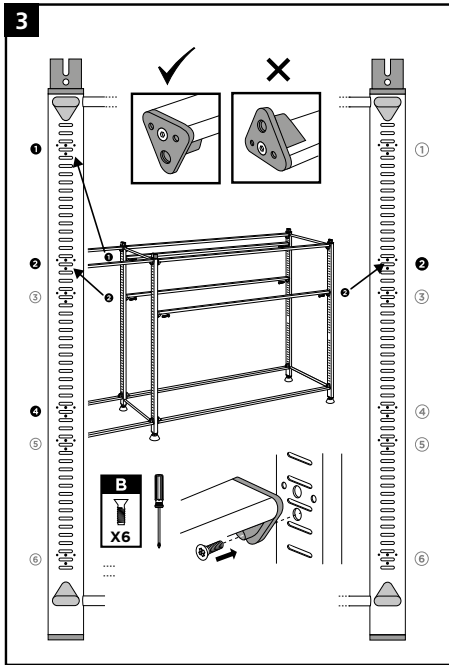

## 5. Tilted tray unit

CFRD44 + CFRB44

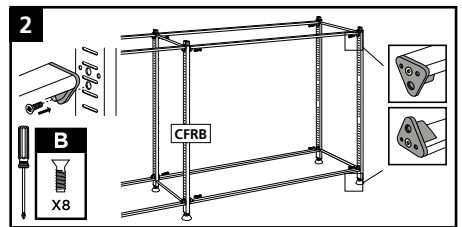
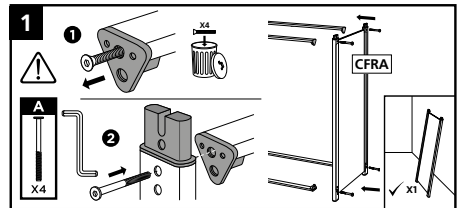
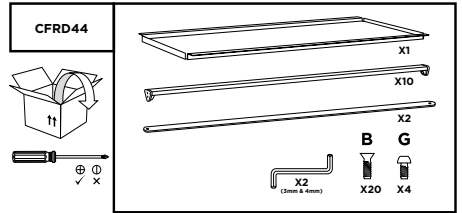

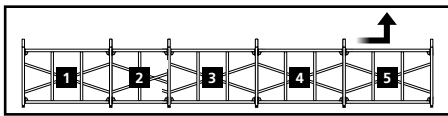
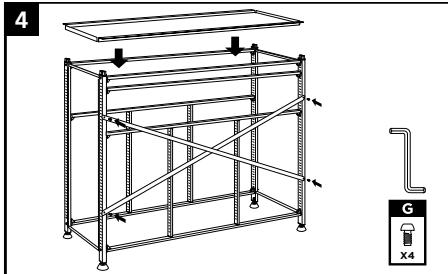
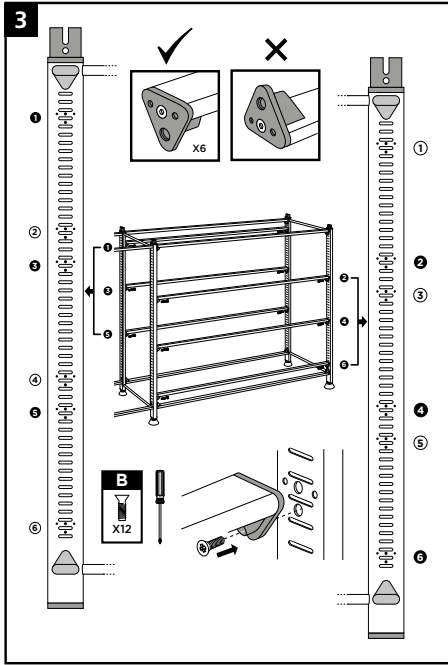

**6. Treble column unit**  
CFRA44 + CFRC44  
+ CFRB44

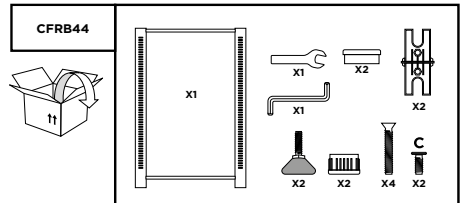
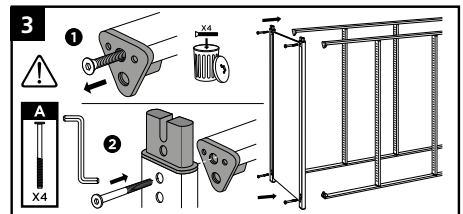
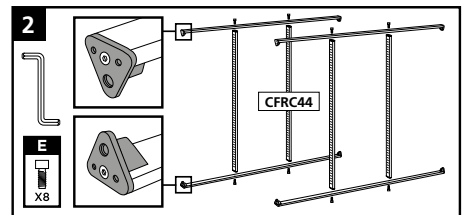
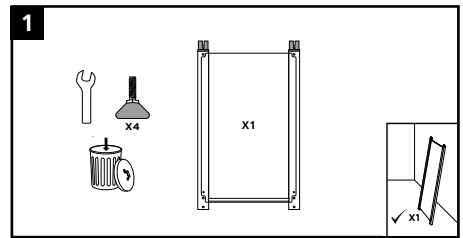
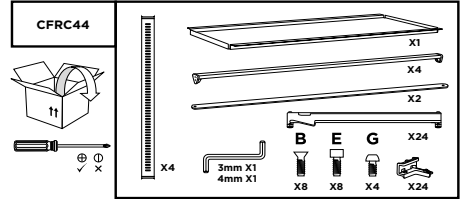
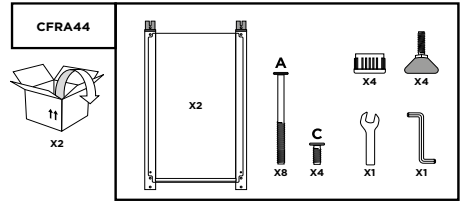

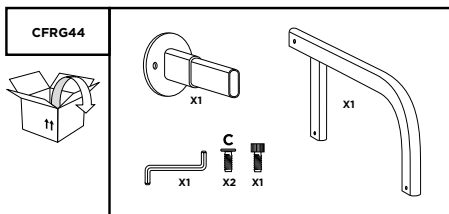
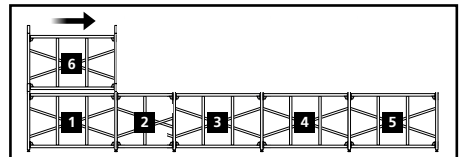
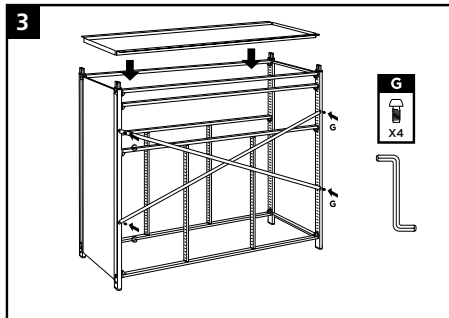
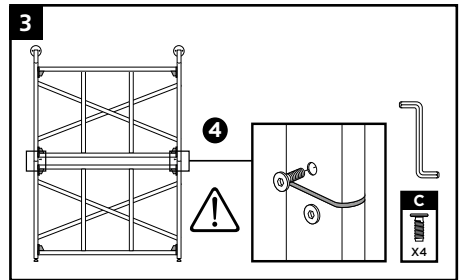
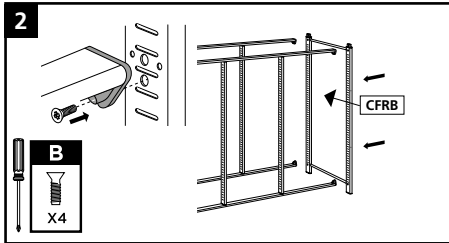
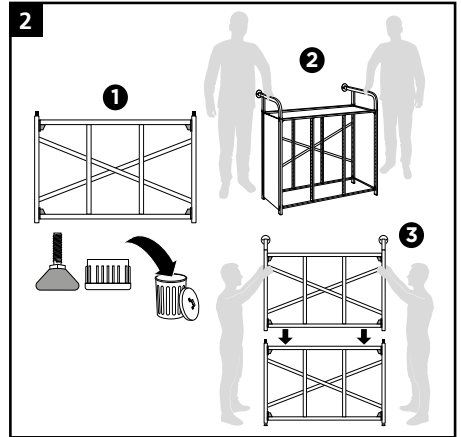
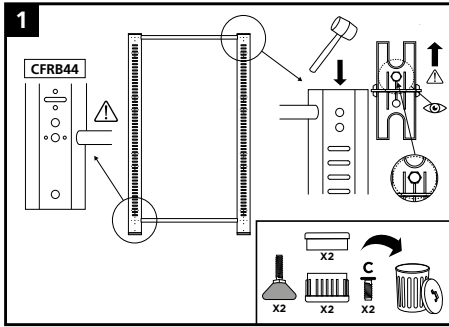

## 7. Double column unit

CFRF44 = CFRB44

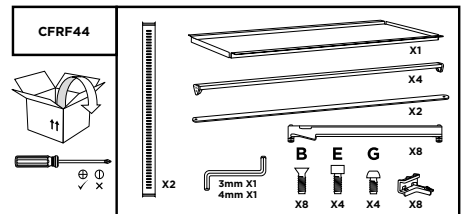
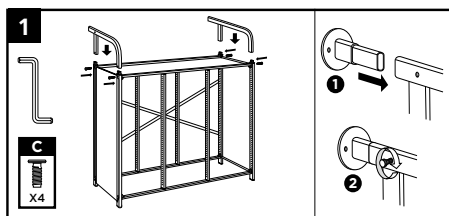

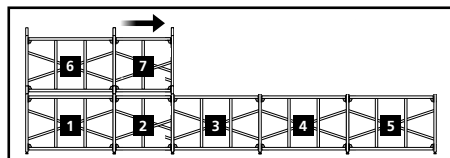
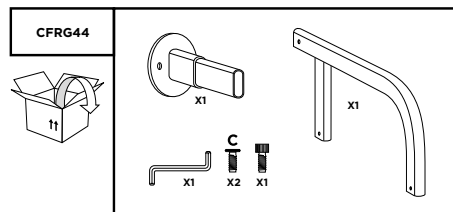
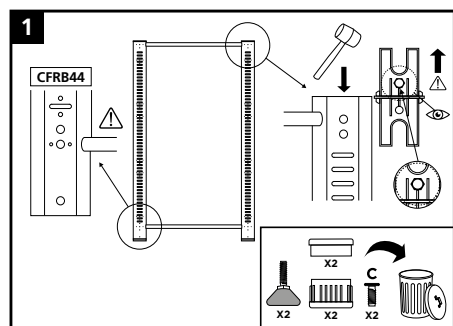
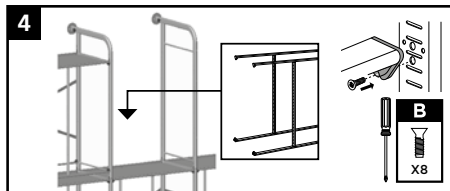
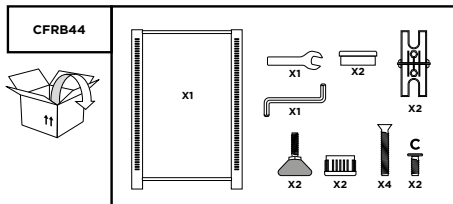
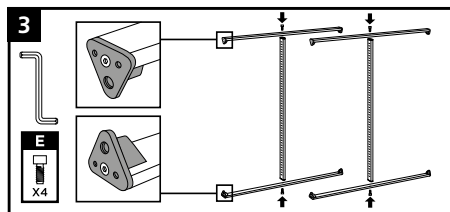
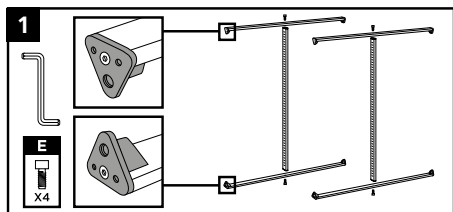

## 8. Flat shelf unit

CFRM44 + CFRB44

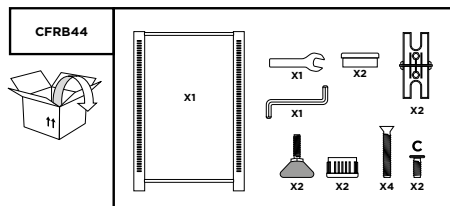
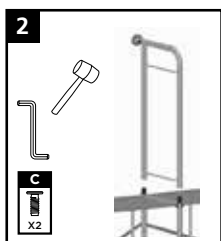
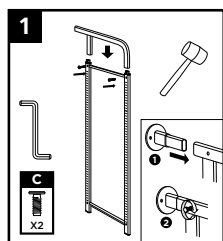



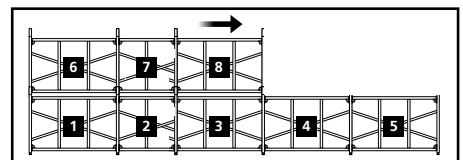
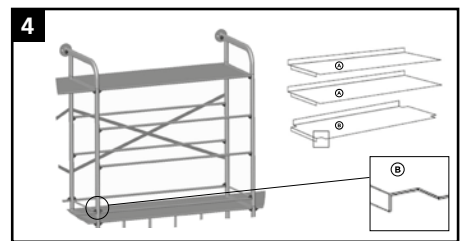
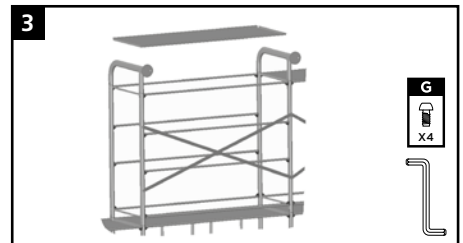
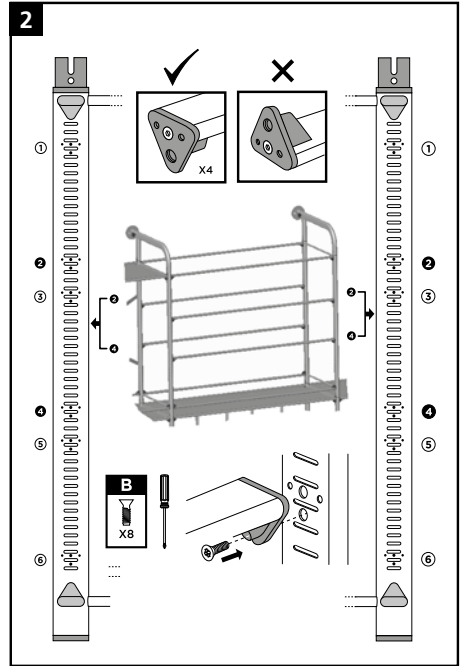
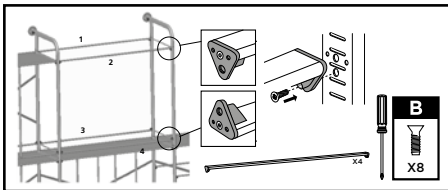
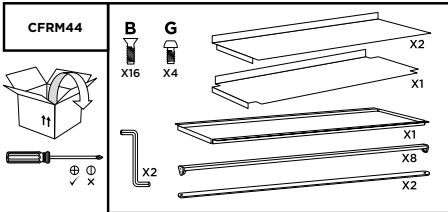
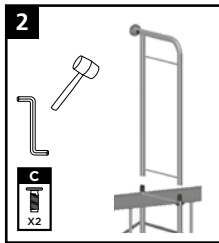
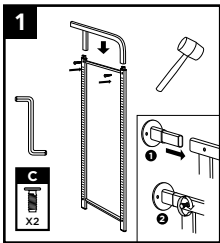
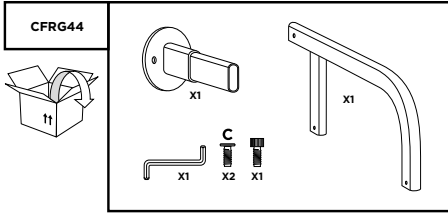
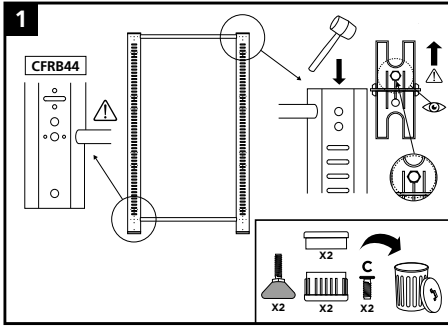

## 9. Treble column unit

CFRC44 + CFRB44

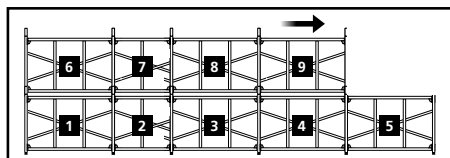
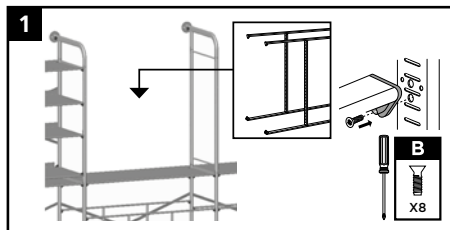
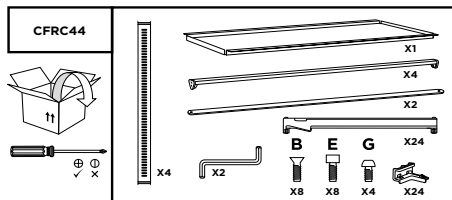
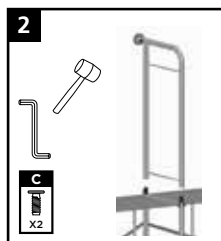
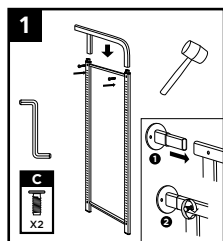
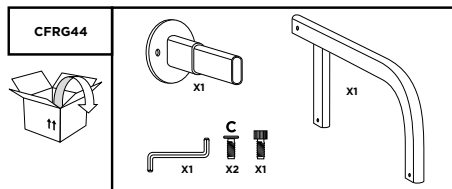
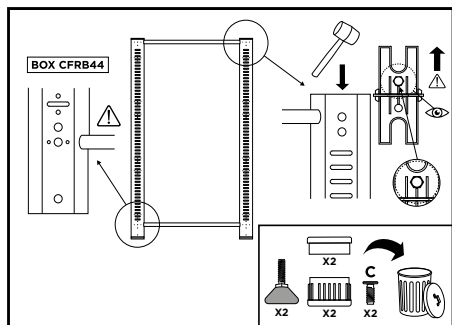
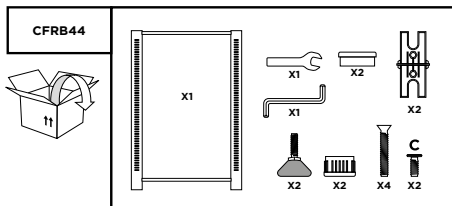

## 10. Treble column unit

CFRA44 + CFRC44  
+ CFRB44

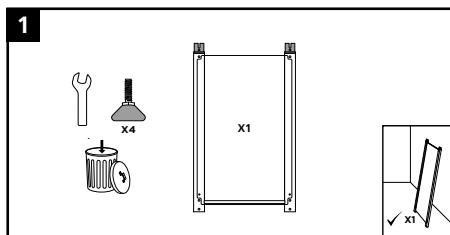
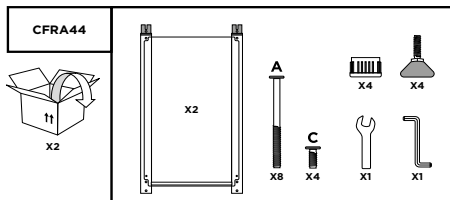

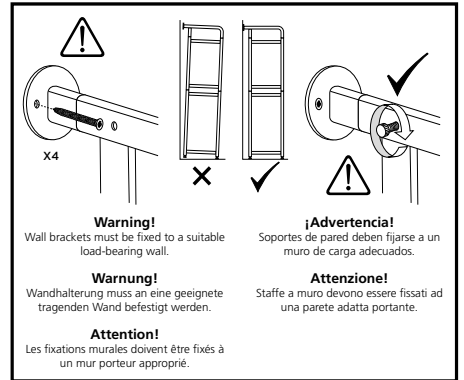
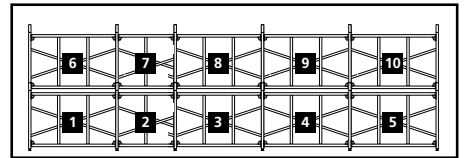
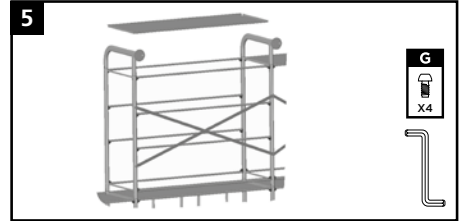
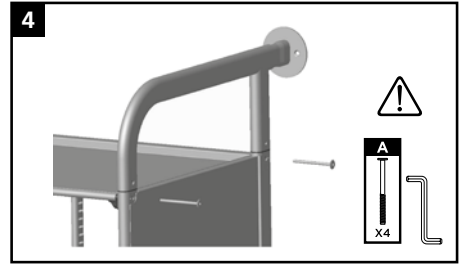
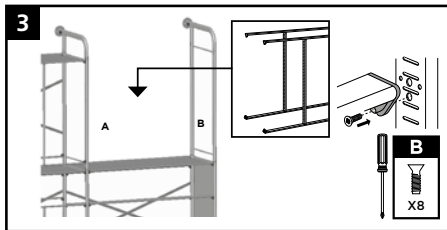
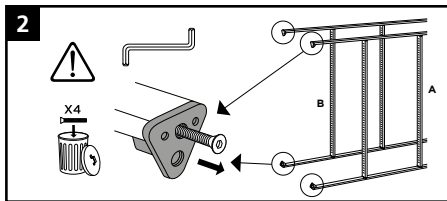
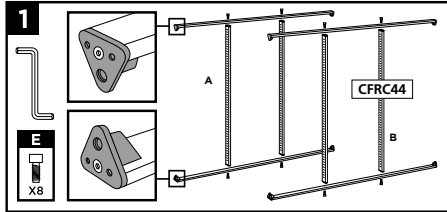
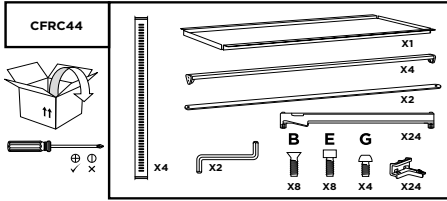
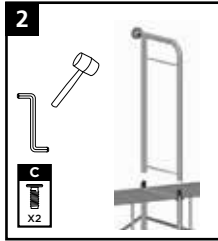
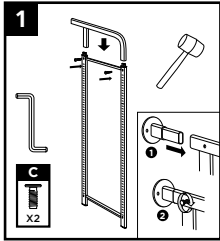
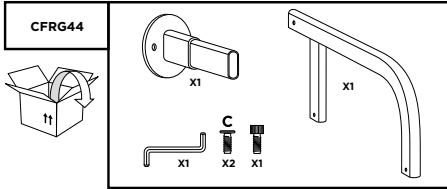

# Runners and Tray spacing guide

